

THE WORLD OF CRANE COMPONENTS



# CERTUS

## HYDRAULIC BUFFERS

 ALWAYS SAFE. ALWAYS THE FIRST CHOICE.

# CERTUS

**ALWAYS SAFE. ALWAYS THE FIRST CHOICE.**

**For reliable and safe crane operations,  
rely on Karl Georg hydraulic buffers**

## CERTUS HYDRAULIC BUFFERS

**Maximum safety and performance with hydraulic buffers from the leading manufacturer Karl Georg. Custom-tuned damping properties and durable, corrosion-protected design for cranes and a variety of other applications.**

### DISCOVER THE PERFECT SOLUTION FOR YOUR COMPANY

Our series of **CERTUS** hydraulic buffers offer effective energy absorption solutions for a wide range of applications, including process cranes, port cranes, steel mills, and more. Available in various sizes and stroke lengths from our standard portfolio, our hydraulic buffers can also be specially adapted to meet the specific requirements of your crane or desired application profile.

### NO COMPROMISES – OUR GUARANTEE

We guarantee a high level of vertical integration at our site in Germany. In addition to rubber and cellulose buffers, we offer a wide range of high-performance hydraulic buffers specifically developed for crane requirements.

These buffers are characterized by high energy absorption and precise motion control, ensuring the crane comes to a safe stop in an emergency.

Our hydraulic buffers are available with a maximum buffer force of 1,000 kN and a stroke length from 50 to 1,600 mm. They are designed for ambient temperatures ranging from

-30 to +100 °C as standard. If needed, they can be easily modified for operating temperatures down to -50 °C.

### ENJOY YOUR FREEDOM AND DECIDE FOR YOURSELF

Our interfaces to steelwork, optional extras and accessories are compatible with similar designs from our competitors, such as OLEO, for example. Our hydraulic buffers offer straightforward integration for any installation scenario.

### MAXIMUM FLEXIBILITY

Our customized safety solutions guarantee unique safety and maximum lifespan for every crane. These solutions can be seamlessly integrated into your crane setup. Rely on the proven standard hydraulic buffers from Karl Georg. Additionally, benefit from individual adaptations specifically tailored to your requirements.





**AUTOMOTIVE**  
Automotive manufacturing, autonomous driving and parts supply



**ENERGY SECTOR**  
Wind power, solar energy, hydropower, geothermal power and biomass



**PLANT ENGINEERING**  
Process engineering, power engineering, supply engineering and production engineering, etc.

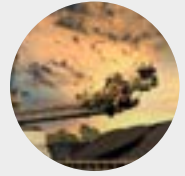

**MINING**  
Exploration, extraction and movement of mineral resources

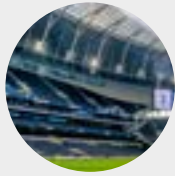

**ENTERTAINMENT**  
Commercial roofs, stage systems, stadium turf, etc.

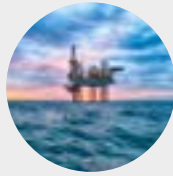

**CONVEYOR SYSTEMS**  
Upstream/downstream, onshore/offshore production, LNG/H<sup>2</sup> logistics



**SMELTING WORKS**  
Steel/metal production and processing



**CRANE ENGINEERING**  
Industrial cranes, process cranes, container handling

## AT A GLANCE



-30 °C TO +100 °C



UP TO 1,000 kN  
BUFFER POWER



50 TO 1,600 mm  
BUFFER STROKE



SIMPLE  
INSTALLATION



HIGH  
AVAILABILITY

## DESIGN AND FUNCTION

In the event of a buffer impact, the hollow piston rod (1) moves into a thick-walled hydraulic tube (2). The hollow piston rod simultaneously acts as a gas reservoir (4). The oil (3) inside the hydraulic cylinder is displaced through defined openings (5) in the throttle tube (6).

The displaced hydraulic oil flows into the newly formed chamber within the hollow piston rod. This movement

shifts the gas piston (7), which acts as a separating piston between the media. This shift compresses the gas inside the hollow piston rod.

The increased pressure acts as a return force, bringing the hydraulic buffer back to its original position.

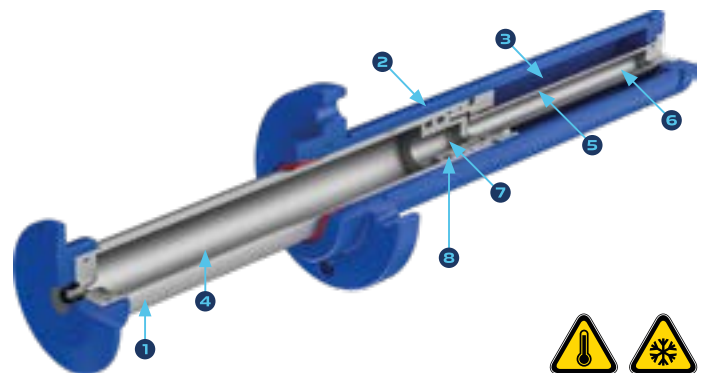

- 1. Hollow piston rod
- 2. Hydraulic cylinder
- 3. Hydraulic oil
- 4. Gas reservoir
- 5. Restrictor openings
- 6. Restrictor tube
- 7. Gas piston
- 8. Sealing system



## INSTALLATION OPTIONS

### DISCOVER POWERFUL SOLUTIONS FOR YOUR BUSINESS

With the front flange variant, the hydraulic buffer is integrated into the steelwork. This is especially significant if the space needed for the buffer needs to be taken into account, as a result of its own length and the resulting risk of it becoming deformed in the plant steelwork.

Regardless of the size of the buffer, we recommend using the front flange design from a stroke length of 600 mm.

As a general rule, this variant allows savings to be made in the installation and travel space within the system.

With the back flange variant, the hydraulic buffer is installed in front of the steelwork.

Here, the hydraulic buffer flange design can also be subsequently incorporated into the existing steelwork. Tests must be made, however, to confirm that the plant can achieve the necessary travel distance.

## FLANGE VARIANTS

### FRONT FLANGE

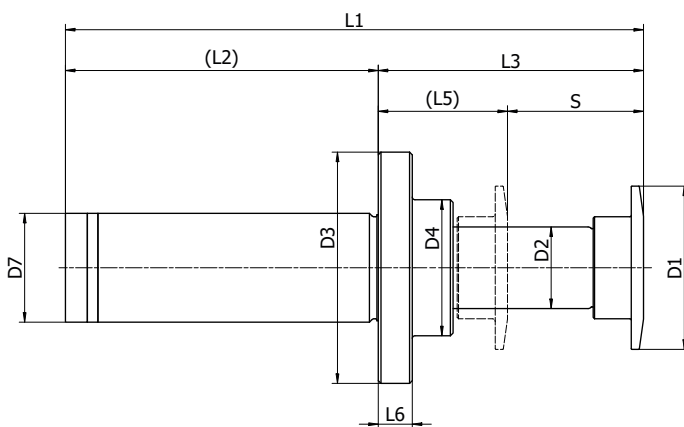

### BACK FLANGE

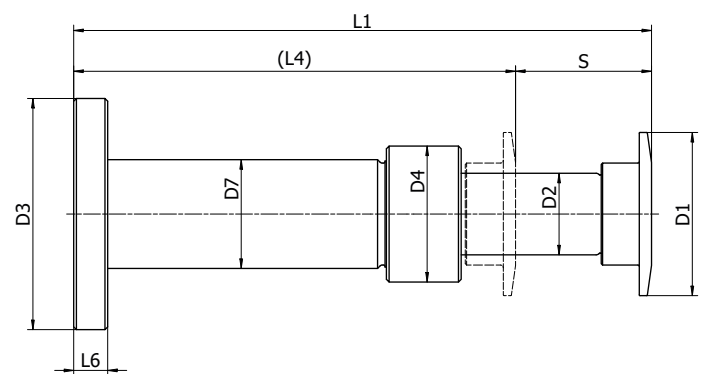

If you are unsure which design provides the greatest value for your application, do not hesitate to contact us. Our experienced application engineers are always available to provide comprehensive advice. Benefit from our many years of expertise and let us work together to develop the optimal system layout for your individual needs.

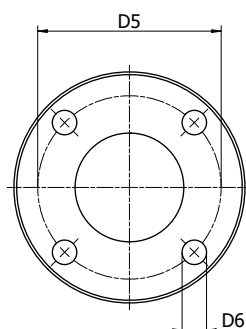
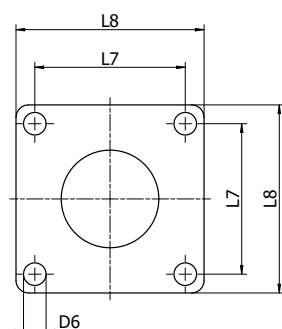

The modular design of our hydraulic buffer series allows for the installation of various flange types.

This ensures that all common flange patterns can be accommodated, enabling the interchangeability of competitor products.

You can find the dimension tables in our current hydraulic buffer main catalog on our website.

# CERTUS PERFORMANCE DATA

Nominal Ø (mm)	Stroke (S) (mm)	max. buffer power (kN)	max. working load/stroke <sup>1)</sup> (kJ/stroke)	max. working load/h <sup>2)</sup> (kJ/h)	Static restoring force		max. angular deviation <sup>4)</sup>		Weight approx. (kg)
					Stroke start <sup>3)</sup> (kN)	Stroke end <sup>3)</sup> (kN)	F (°)	B (°)	
75	100	200	20	1300	1.4	13.5	4.3	3.2	22
	150	200	30	1850		17.5	3.2	2.4	24
	200	200	38	2500		17.2	2.5	1.9	26
	300	180	50	3350		16.4	2.0	1.5	28
	400	160	55	3700		15.2	1.7	1.3	30
	500	140	58	3900		13.8	1.6	1.2	32
	600	120	60	4000		13.6	1.5	1.1	36
95	100	260	25	1600	2.3	12.8	5.0	4.4	23
	150	260	37	2300		15.8	4.5	3.3	26
	200	260	49	3100		15.0	4.0	2.6	30
	300	250	67	4100		18.0	3.0	1.9	36
	400	230	82	5100		21.0	2.5	1.6	41
	500	210	92	6100		20.3	2.2	1.5	46
	600	190	100	7100		20.0	2.1	1.4	53
	800	150	105	9100		19.0	2.0	1.3	67
115	100	520	49	3150	3.7	16.4	5.0	4.5	44
	200	520	97	6150		19.3	3.9	3.1	56
	250	520	115	7650		21.2	3.2	2.6	62
	300	480	133	9150		21.6	3.0	2.4	68
	400	440	162	12150		22.1	2.5	2.0	81
	500	400	185	13600		23.1	2.2	1.8	90
	600	360	198	15100		25.9	2.1	1.7	98
	800	300	220	17100		26.4	1.9	1.5	130
135	200	700	127	8000	5.5	70	4.5	3.5	72
	300	650	177	12000		70	3.1	2.5	89
	400	650	236	15000		75	2.7	1.7	99
	600	550	300	17000		75	2.3	1.3	125
	800	450	327	19000		75	1.7	0.9	160
	1000	400	364	21000		75	1.3	0.7	192
	1200	400	436	23000		75	1.0	0.6	225
175	200	1000	182	8000	9.5	80	6.0	5.0	105
	400	950	345	14400		80	5.0	4.0	165
	500	900	409	17500		90	4.5	3.5	195
	600	860	469	20500		95	4.0	3.0	230
	800	750	545	25000		100	3.0	2.0	290
	1000	600	545	28000		110	2.3	1.3	350
	1200	500	545	28000		110	1.7	0.8	410
	1600	400	582	32000		110	1.5	0.6	530

<sup>1)</sup> for standard characteristic  
Nominal buffer speed 0.5 to 4.0 m/s, lower or higher speed on request

<sup>2)</sup> at 30 °C ambient temperature

<sup>3)</sup> at 5 bar gas pressure

<sup>4)</sup> at max. buffer power



## FURTHER INFORMATION

Need more detailed information about our CERTUS hydraulic buffers?  
Please consult our catalogue on [www.karl-georg.de](http://www.karl-georg.de)



## TECHNICAL AND BUSINESS BENEFITS



**PRECISE  
ADAPTATION**



**LONG  
SERVICE LIFE**



**DEFINED  
RESIDUAL FORCE**



**HIGH LEVEL OF  
PLANT SAFETY**



**ACCURATE LOAD  
ANALYSIS**



**GET A QUOTE TODAY!**

Use our customer-friendly quote form to obtain your individual quotation.

[www.karl-georg.de/downloads](http://www.karl-georg.de/downloads)

## OPTIMUM SOLUTION

**PRECISE ADAPTATION POSSIBLE**

Karl Georg hydraulic buffers can be precisely adapted to the specific requirements of your application. The functionality and damping characteristics are calculated based on your customer data and precisely implemented before delivery.

In contrast, competitor products often only offer an imprecise buffering spectrum (min. – max.) and are usually offered as standard solutions that do not adequately meet the requirements to protect the components in the force flow.

**ACCURACY OF STRESS**

With our buffers, you receive accurate information about the loads to which the components and structures of your crane are subjected.

**DEFINED RESIDUAL FORCE**

Our expertise allows for the precise calculation of the buffer characteristic curve with a defined residual force. This ensures a significant increase in safety and longevity.

## ADDITIONAL BUFFERS AND DAMPING SYSTEMS

**GREAT PRODUCTS FOR  
GREATER RELIABILITY**

Our product portfolio offers a wide range of solutions for the safe control of defined loads and speeds. We manufacture in Germany, and thanks to our stocked inventory, our products are always immediately available. For custom adjustments, we are available on short notice to provide tailored solutions.

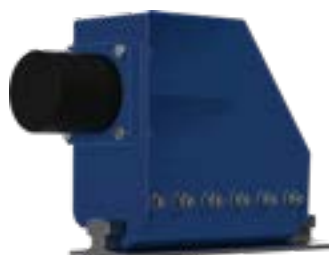

Bumper



Cellular plastic and rubber buffers

# XTREM WE PUSH BOUNDARIES

With decades of experience, Karl Georg offers a variety of specific product solutions for special applications, conditions, and interfaces.

Thanks to flexible manufacturing concepts and high vertical integration, we can provide customized solutions starting from a quantity of one.

We are happy to support you with your project specifications.

- **Low temperatures down to -30 °C**  
Adaptations for conditions down to -50 °C available
- **High temperatures up to +100 °C**  
Higher temperatures possible with adaptations
- **Indoor, outdoor, offshore**
- **Corrosion protection C1 – C5M**  
Effective saltwater protection available
- **Special flange**



## OPTIONAL EXTRAS AND ACCESSORIES



## CORROSION PROTECTION ON DEMAND

Standard corrosion protection with high-quality 2K primer. Multi-layer coating systems up to C5-M in any desired RAL color available upon request starting from batch size 1.

Flexibility and creativity are the guiding principles of our products. Innovation is our driving force. Whatever you plan, we provide the suitable product.





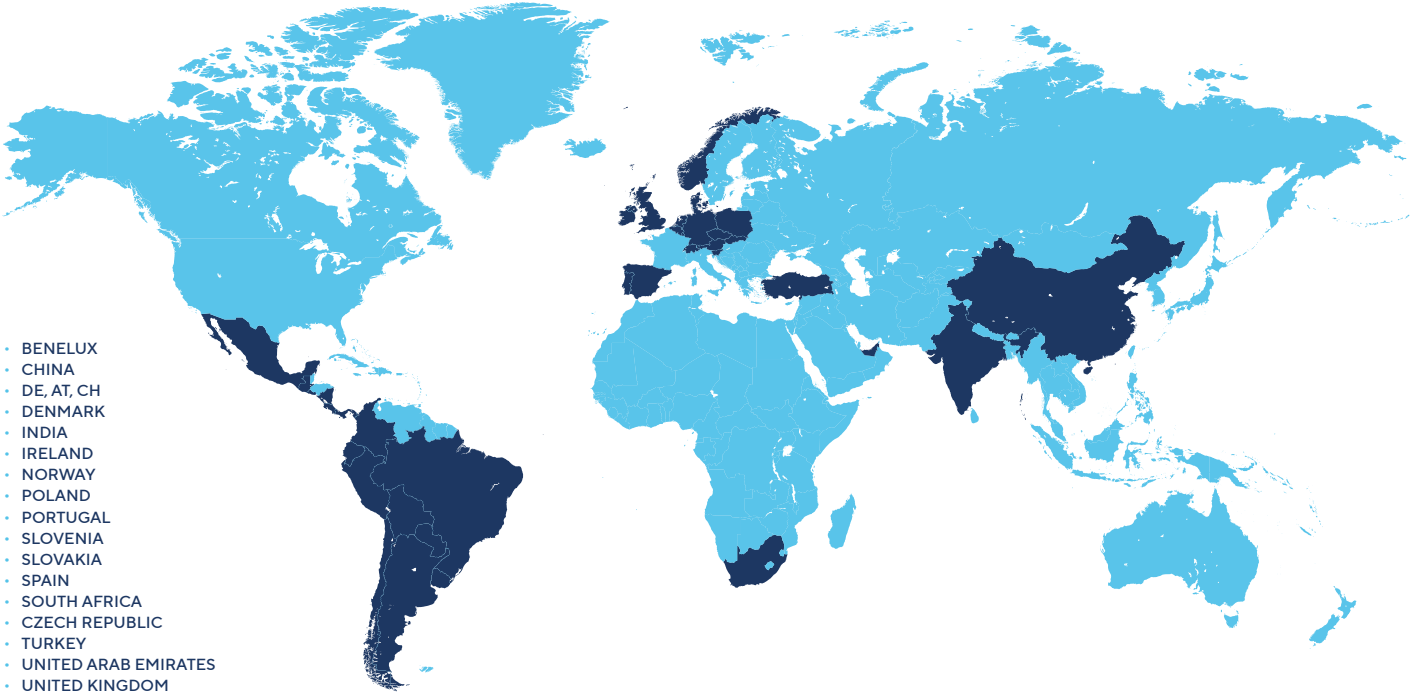

- BENELUX
- CHINA
- DE, AT, CH
- DENMARK
- INDIA
- IRELAND
- NORWAY
- POLAND
- PORTUGAL
- SLOVENIA
- SLOVAKIA
- SPAIN
- SOUTH AFRICA
- CZECH REPUBLIC
- TURKEY
- UNITED ARAB EMIRATES
- UNITED KINGDOM

## FURTHER INFORMATION

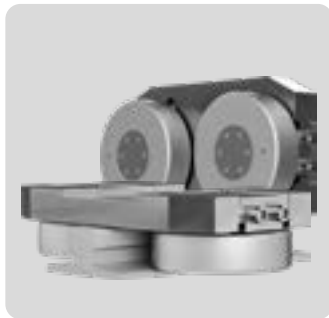
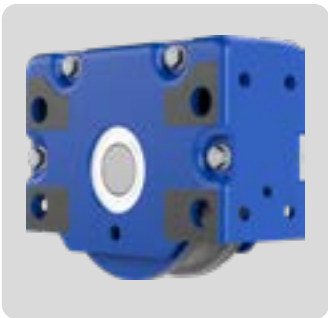

FOR MORE  
INFORMATION, PLEASE  
VISIT OUR WEBSITE AT  
[KARL-GEORG.DE](http://KARL-GEORG.DE)



**KARL GEORG GMBH**  
Karl-Georg-Straße 3  
D-57612 Ingelbach-Bahnhof  
T: +49 2688 / 95 16 - 0

info@karl-georg.de  
www.karl-georg.de

WE HAVE DIN  
ISO 9001, ISO 14001  
AND DIN EN 16247-1  
CERTIFICATION.



Subject to change without notice, E&OE.  
© 2024 Karl Georg GmbH