

Crane wheels with plain bearing with gear ring

DIN 15 075



Designation of a travel wheel form BG with nominal-
Ø d1 = 630 mm,
gauge b1 = 100 mm, hub symmetric (l1 = l2 = 185 mm):

Crane wheel BG 630 × 100 DIN 15 075

Form SK narrow crane wheel (S) with small gear ring (K)

Form SG narrow crane wheel (S) with large gear ring (G)

Form BK broad crane wheel (B) with small gear ring (K)

Form BG broad crane wheel (B) with large gear ring (G)

The plain bearings are secured with setscrews toward twisting and dislocation.

Gear rings see DIN 15 082 part 1.

Material:

Wheel body-Ø 200–250 C45 machined from solid

Wheel body-Ø 315–1250 GE420 (GS-70) or

G42CrMo4+QT (GS-42CrMo4V)

Bearing G-CuSn7ZnPb (Rg 7)

Gear ring GE300 (GS-60) or C45

Other material and dimensions on request.

Crane wheels without gear ring see DIN 15 074.

See DIN 15070 for basis of calculation for crane wheels.

Remarks to the following table:

- 1) The dimension of the gauge recess b1 to be stated with order. For running surface profiles and correspondence of crane rails to running wheel diameter see DIN 15072.
- 2) Asymmetric hubs (diameter l₁) as per agreement.
- 3) For l1 = 90 mm is a slide bearing length of l3 = 120 mm to use.
- 4) For l1 = 125 mm is a slide bearing length of l3 = 180 mm to use.

Crane wheels with plain bearing with gear ring

DIN 15 075

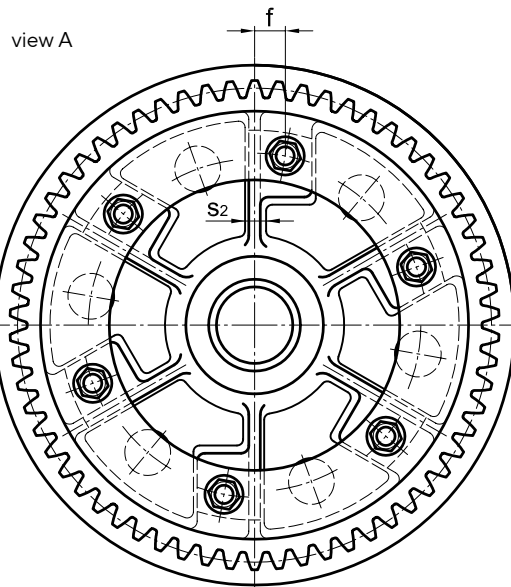
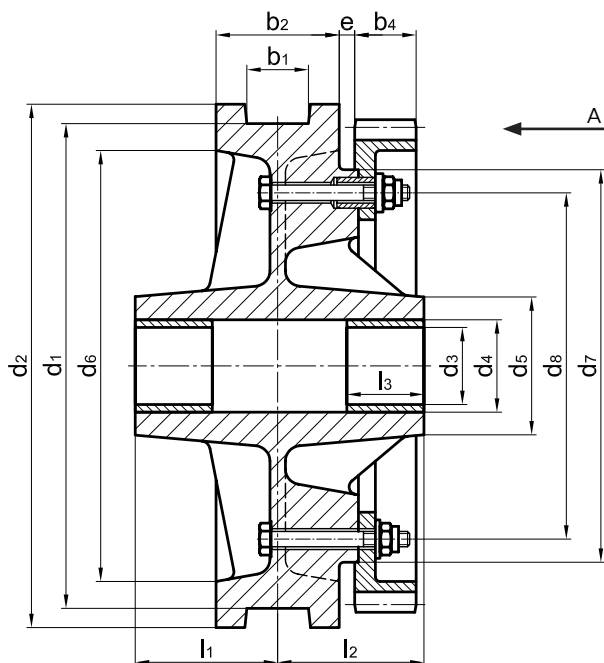

Form	d1	b1 ¹⁾	b2	l1 ²⁾		l2	d2	d3 D10	d4 H7	d5	d6	d7	d8	gear ring (form A)			e	f	l3	s1	s2	no. of ribs and cams	unit weightt ≈[kg]	
				sym- me- tric	asymme- tric									Mo- dule	no of teeth	b4								
SG	200	40-55	90	105	80	60	105	230	45	55	85	170	160	125	5	40	40			45				35
SG	250	40-55	90	115	85	60	115	280	50	60	100	210	200	155	5	50	50	15	-	50	18	-	without Ribs 4	58
SG	315	45-55	90	125	95	65	125	350	60	75	120	270	260	200	6	52	60			63				76
BG		55-65	110	135	105	75	135																	
SK	400	55-65	110	140	105	75	140	440	80	95	140	345	270	210	8	40	65	15	-	80	20	-	without Ribs 4	92
SG													300	240		50								102
BK	70-90	140	155	120	90	155							270	210	8	40	15	-	80	20	-	without Ribs 4	146	
BG													300	240		50							156	
SK	55-65	110	145	110	75	145							350	290	10	42	70	15	35	90	20	15	4	163
SG													390	330		49								173
BK	70-90	140	160	125	90	160	540	90	105	160	435		350	290	10	42	70	15	35	90	20	15	4	202
BG													390	330		49								212
SK	65-75	120	165	120	80	165							460	400	10	54	80	20	40	100	20	15	6	300
SG													510	450		62								315
BK	80-110	160	185	140	100	185	680	100	120	180	560		460	400	10	54	80	20	40	100	20	15	6	342
BG													510	450		62								357
SK	75-90	140	185	135	90	185							510	450	12	50	90	20	40	110	25	18	6	412
SG													580	520		58								437
BK	95-160	210	220	170	125	220	760	110	130	200	630		510	450	12	50	90	20	40	110	25	18	6	519
BG													580	520		58								544
SK	75-90	140	195	140	90	195							610	550	12	58	100	20	40	125	25	18	6	523
SG													660	600		66								543
BK	95-160	210	230	175	125	230	850	125	145	220	710		610	550	12	58	100	20	40	125	25	18	6	543
BG													660	600		66								658
SK	75-90	140	205	145	90	205							680	620	14	56	110	20	40	150	25	18	6	550
SG													750	690		63								580
BK	95-160	210	240	180	125	240	950	140	160	240	805		680	620	14	56	110	20	40	150	25	18	6	700
BG													750	690		63								730
SK	75-90	140	205	145	90	205							790	710	14	64	110	20	50	150 ³⁾	30	20	6	725
SG													840	760		70								750
BK	95-160	210	240	180	125	240	1050	160	180	270	900		790	710	14	64	110	20	50	150 ³⁾	30	20	6	885
BG													840	760		70								910
BK	95-160	220	260	190	125	260	1180	180	200	300	1010		880	800	16	62	125	20	50	180	30	20	8	1170
BG													950	870		68								1220
BK	95-160	220	260	190	125	260	1310	200	220	330	1140		1000	920	16	70	125	20	50	200 ⁴⁾	30	20	8	1360
BG													1080	1000		76								1400

footnote see page 34