

Crane wheels

for driven- and nondriven wheel sets acc. to DIN 15 090

DIN 15 093



Form S narrow crane wheel



Form B broad crane wheel

Designation of a wheel form B with nominal- \varnothing d1 = 630 mm, gauge b1 = 100 mm, bore- \varnothing d3 = 180 mm H7:

Crane wheel B 630 × 100 × 180 H7 DIN 15 093

Form S narrow crane wheel

Form B broad crane wheel

All wheels on demand with oil pressure connection acc. to DIN 15 055.

Material: GE420 (GS-70) or
G42CrMo4+QT (GS-42CrMo4V) or
42CrMo4+QT (42CrMo4V) drop forged

Other material and dimensions on request.

All functional dimensions are binding. The design of the wheel depends on the manufacturer.

Basis for calculation for crane wheels see DIN 15 070.

Our high resilient, forged crane wheels are available in the following alternatives:

- 42CrMo5-04 quenched and tempered to 850-1000 N/mm² or higher
- 42CrMo5-04 quenched and tempered tread - and inner wheel flanges non-slip hardened to HRc 48-54, hardening depth min. 10 mm
- 42CrMo5-04 quenched and tempered tread and inner wheel flanges deep hardened to 450-500 HB, hardening depth 18-20 mm

Crane wheels

for driven and non driven wheel sets acc. to DIN 15 090

DIN 15 093

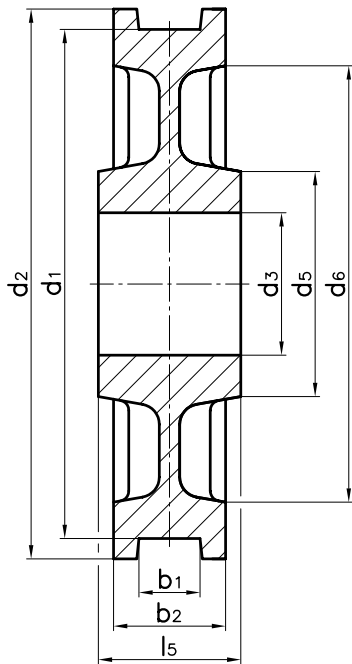

Form S narrow crane wheel

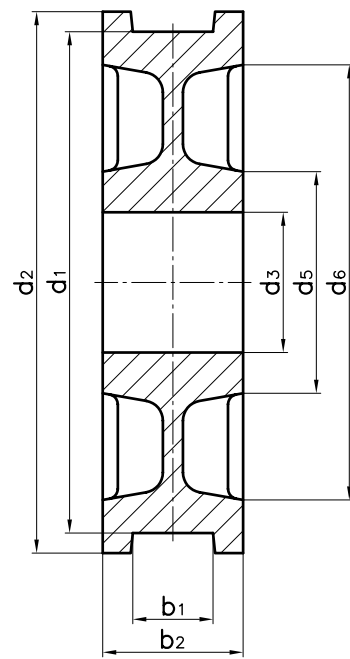

Form B broad crane wheel

form	d1	b1 ¹⁾	b2	d2	d3 ²⁾	d5	d6	l5	no.of ribs	unit weight
	h9				H7					≈[kg]
S	315	45-55	90	350	70-110	175	270	110	-	51
B		55-65	110		80-120	190				65
S	400	55-65	110	440	80-120	190	345	140	-	82
B		70-90	140		90-130	205				105
S	500	55-65	110	540	90-130	205	435	140	6	120
B		70-90	140		100-140	220				138
S	630	65-75	120	680	100-160	255	560	150	6	190
B		80-110	160		120-180	285		235		
S	710	75-90	140	760	120-170	270	630	180	6	255
B		95-160	210		140-190	300		358		
S	800	75-90	140	850	140-180	285	710	180	6	315
B		95-160	210		160-200	320		450		
S	900	75-90	140	950	140-190	300	805	190	6	375
B		95-160	210		180-230	365		600		
S	1000	75-90	140	1050	160-200	320	900	190	6	490
B		95-160	210		200-250	395		750		

1) The dimension of the gauge recess b1 to be stated with order. For running surface profiles and correspondence of crane rails to running wheel diameter see DIN 15072.

2) Bore dimensions-Ø d3 to be stated with order.