

Installation and Maintenance Instructions

ATLAS

WHEEL BLOCK SYSTEM

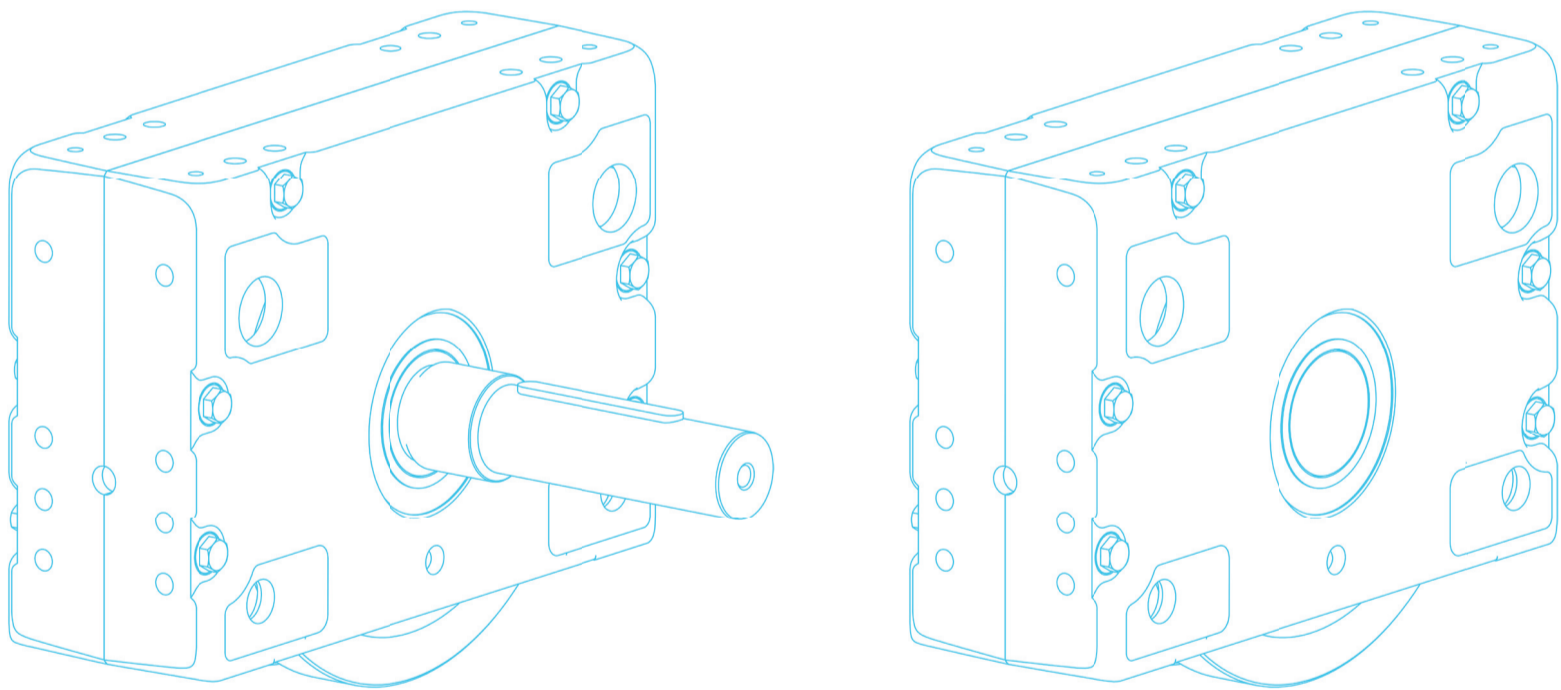

RB 400

Foreword

Thank you very much on deciding on a product from the company KARL GEORG.



These Installation and Maintenance Instructions contain all information required for the installation, as well as for safe operation and maintenance of the wheel blocks. Before installation and commissioning, carefully read these. The operating personnel must have access to these instructions at all times.

KARL GEORG accepts no liability for damage and operating malfunctions that result from the not-observance of these Installation and Maintenance Instructions.

Intended Use

The KARL-GEORG wheel blocks are used in conveyor-related systems, as well as in the overall field of machine construction and enable flexible transportation tasks. Due to the all-round processed mounting surfaces and the connection elements available as an option, there are numerous connection options. The drive shafts can be designed to adapt to slip-on gear mechanisms of all makes.

The Wheel block body comprises of two halves of a precise fitting, machined housing attached by bolts. Thereby, the expendable “crane wheel” and the spherical roller bearing can be quickly and economically replaced using commercially available tools.

Materials: Crane wheel EN-GJS-700 (GGG-70)
Housing EN-GJS-400 (GGG-40)

The connection holes in the housing and the associated connection elements provide flexible options for precise connection. During delivery, plastic plugs protect all connection bore holes.



The plastic plugs can be used at temperatures of -40 °C to +60 °C. If the wheel blocks are used outside this temperature range, as well as in the ATEX area, the plastic plugs must be removed before commissioning.

Colour

Standard: The wheel block housing and crane wheel body are provided with an anthracite-coloured 1-K corrosion protection primer at the works. These feature good paintability, corrosion-resistance and resistance to the weather.

Special colour: On request, the wheel blocks can be designed with a primer, intermediate and top coat.

Predictable incorrect use

Not-observance of these Installation and Maintenance Instructions and/or the main catalogue can result in an impermissible use of the wheel block system.

Thereby, under unreasonable conditions, malfunctions, failure or risk to life and limb can occur.

The situations given below result in, e.g. impermissible use:

- | | |
|---------------|--|
| Design: | <ul style="list-style-type: none"> - Impermissible or unconsidered load peaks - Unconsidered extreme ambient conditions - Impermissible application temperatures |
| Installation: | <ul style="list-style-type: none"> - Incomplete use of installation elements - Using installation elements from third parties - Insufficient alignment of the wheel blocks to the track |
| Maintenance: | <ul style="list-style-type: none"> - Not-observance of the lubrication intervals under extreme conditions - Not-observance of the tightening torques for the connection bolts and/or the inspection intervals. |

Maintenance

Because of the technical construction of the KARL GEORG wheel blocks, under normal operating conditions, they are fundamentally maintenance-free.

Bolted fittings

Check the connection bolts for the drive shafts using a torque wrench after the initial 3 - 6 operating hours or approx. 100 load reversals (tightening torque 360 Nm).

After a further three months operating time, tighten all bolted fittings to the specified tightening torque, subsequently, as required in accordance with the conditions of use and operating conditions, however, a minimum of once a year (refer to BGV D6 UVV cranes).

Roller bearings

The spherical roller bearings are lubricated.
Lubricating intervals adapted to the respective conditions of use.

Before delivery, the roller bearings are lubricated with the following greases:

- a) **Series** Product: Multifak EP 2
Manufacturer Texaco
- b) **Higher temperatures $\leq 200\text{ °C}$** Product: OKS 424
Manufacturer OKS

Equivalent lubricants can be used, however, compatibility with the original lubricant must be ensured.

- c) **For operation in the Ex-area, the special grease OKS 464 (manufacturer OKS) must be used.**

After commissioning, slight escape of grease can occur at the seals, these should be removed and disposed of in an environmentally-friendly manner!

Material fatigue/crane wheel wear

Depending on the individual case, wheel block and drive shafts must be checked at regular intervals for corrosion, material fracture (in particular fracture of shafts) and for correct alignment.

The running surface and wheel flanges must be checked a minimum of every three months for wear and/or damage.
The crane wheel unit must be replaced when one of the following limit values is attained:

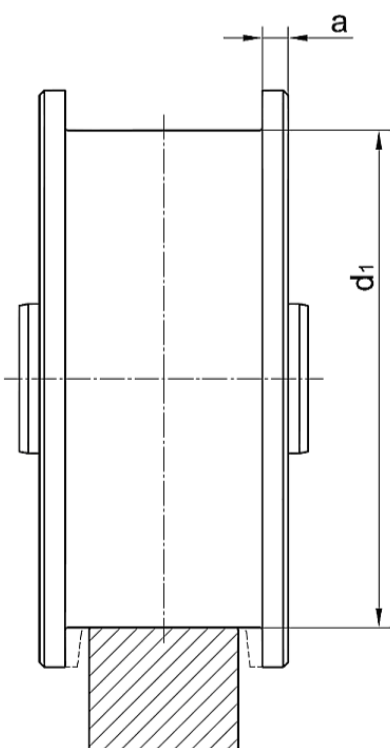

Table of limit values for wear

Size of crane wheel (RB ...)	smallest wheel flange width a	smallest crane wheel-Ø d1
160	7,0	153,5
200	8,5	193
250 / 250-V	9,5	242
315	11	307
400	13	392

On request, wheel blocks can be sent for servicing.

In order to minimize wear on the crane wheel, the wheel blocks should be correctly aligned and the rail free of contamination. Furthermore, on request, there is the option of hardening the running surfaces and inner surface of the wheel flanges so that they are anti-slip, in order to increase the service life of the crane wheels.

Storage

- The wheel blocks must be stored in a dry place
- The crane wheels must be rotated every six months
- Before use, the wheel blocks must be lubricated whilst rotating the crane wheel

Possible faults and rectification

- Increased wear on the running surface and/or wheel flange
- Running noises

Track contaminated?

The rail should be protected from excessive contamination, e.g. by regular cleaning. As required, a rail cleaner should be used.

Misalignment of the wheel blocks?

Wheel blocks should be checked at regular intervals for correct alignment. If misaligned, realignment is required.

If a bearing is defective, the complete crane wheel unit must be checked and the defective parts replaced. Here, observe the chapter for Removal and Installation of the wheel block. On request, the defective wheel blocks can be sent for servicing.

Permissible wheel loads

Size of crane wheel (RB ...)	Wheel load in kg*
160	6.800
200	10.000
250	12.800
250-V	16.000
315	22.000
400	30.000

*the a.m. values apply to the use under optimum conditions. At temperatures >150 °C, the wheel loads reduce.

Weight of wheel block

Size of crane wheel (RB ...)	Weight in kg
160	ca. 21
200	ca. 33
250	ca. 52
250-V	ca. 57
315	ca. 90
400	ca. 165

Roller bearings

Series

Sealing is carried out on both sides by special seals made from POM. The spherical roller bearings are lubricated.

Can be used at temperatures of 30 °C to +90 °C. (temporarily up to 130 °C).

Special sealing

Sealing is carried out on both sides using Nilos rings with additional protective discs made from steel. The spherical roller bearings are lubricated.

Used for extreme environmental conditions (dust, heat, moisture etc.) at temperatures from 30 °C to 140 °C.



It is possible to lubricate the wheel blocks.
Lubricating intervals adapted to the respective conditions of use.

Higher temperatures

Sealing is carried out on both sides using Nilos rings with additional protective discs made from steel. The spherical roller bearings are lubricated using OKS 424 high temperature grease.

Can be used at temperatures of -25 °C to + 200 °C.

Lubrication intervals and quantity of grease for high temperature bearing grease Type OKS 424

Reduction factors:

Dust and humidity	x	0,4 - 0,7
Vibration and oscillations	x	0,4 - 0,7

Lubrication as a consequence of heat influence of

110°C	after	16.000 hours
125°C	after	8.000 hours
140°C	after	4.000 hours
155°C	after	2.000 hours
170°C	after	1.000 hours
185°C	after	500 hours
200°C	after	250 hours

Minimum quantity of grease for each bearing: 14 cm³

ATEX

Sealing is carried out on both sides using Nilos rings with additional protective discs made from steel. The spherical roller bearings are lubricated using OKS 464 (electrically conductive) high temperature grease.

Suitable for temperatures of -20 °C to +60 °C.

Lubrication is carried out depending on the temperature and operating time of the wheel blocks.

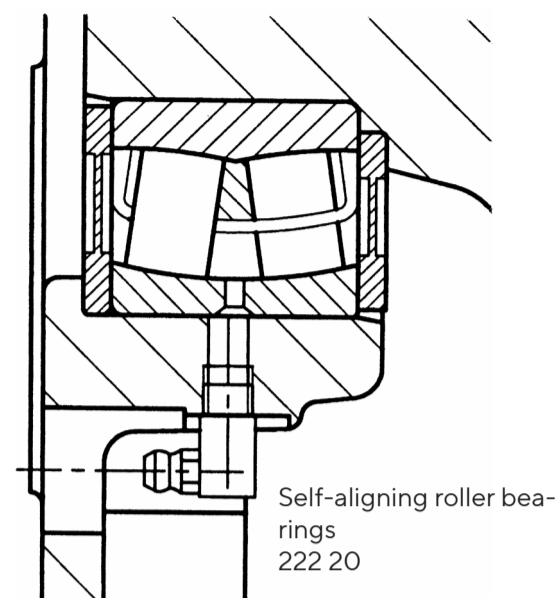

Self-aligning roller bearings
222 20

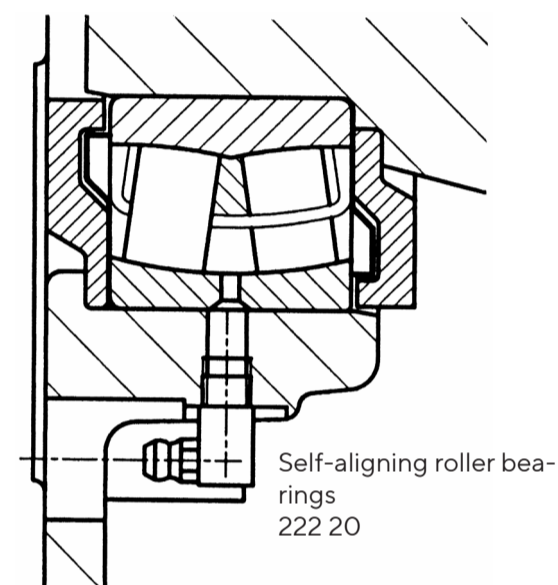

Self-aligning roller bearings
222 20

ATEX (EX-protection)

Application in potentially explosive areas in accordance with the Directive 94/9/EC ("ATEX 95")



Permitted application

The application of wheel blocks in potentially explosive areas is only permissible when the following instructions are observed, in order to ensure safe and correct application.

Drive speed

Relative speeds of the wheel blocks within the **Zone 1 and 21** of less than **1 m/s** are permitted. Monitoring of the travel speeds should always be carried out in Zone 1 and 21. For operation with a frequency converter in Zone 2 and 22 and travel speeds of more than 1 m/s, speed monitoring of the crane wheels must be carried out.

Electrical voltage

The wheel blocks must be permanently conducted to the complete system, the complete system can be individually earthed. If that cannot be ensured under all circumstances, additional methods of ensuring the electronic contact must be installed (e.g. contact brushes). The equipotential bonding must be regularly checked by the operating company. The operating company and equipment manufacturer must ensure sufficient protection against straying currents.

Drive

In potentially explosive areas, only Ex-protected motors with special Ex-protected frequency converters must be operated under consideration of the interconnection.

Track

Pay attention to the material used for the tracks. No light metals should be used. Furthermore, the material must be low-sparking, in the terms of Directive 94/9/EC and not-corrosive.

Temperature

For operation in Zone 1 and 21, monitoring of the bearing temperature must be ensured. During braking, friction heat can be generated. Possibly must be measured after installation of the wheel blocks in the complete system.

Prevention of accident

Fundamentally, make sure that no collisions can occur whilst travelling. Impacting obstacles at high speeds should be unconditionally prevented. Possibly protection systems to prevent accidents must be installed. Accident prevention can be attained by using, e.g. light barriers or end limit switches. In any event, provide an adequate brake path.

Identification

The wheel block from the company KARL GEORG represents an "incomplete machine" in accordance with the Machinery Directive 2006/42/EC (definition refer to Article 2 Letter g).

Thus, wheel blocks from the company KARL-GEORG are not committed to having the "CE" mark and only have the ATEX-Directive 94/9/EC ("ATEX 95"), if these are approved for potentially explosive areas.

Zone 1 and 21:



Zone 2 and 22:



Identification in accordance with RL94/9/EG Appendix II Para.1.0.5

ATEX (EX-protection)

Application in potentially explosive areas in accordance with the Directive 94/9/EC ("ATEX 95")



Design measures

The wheel block is only approved for Zones 1/21 and 2/22 with the mark in accordance with the ATEX-Directive.

If using the wheel blocks in potentially explosive areas, these must be designed with special seals (refer to Page 5) and using electrically conductive grease OKS 464.



Plastic plugs for application in ATEX-area are not permitted.

In addition, only applicable for Zone 1 and 21:

- The cellular plastic buffers PU 70...210 are not permitted.
↳ A material must be used that can verify a surface resistance of less than 1 GΩ
- The speed must be monitored, particularly when operating using frequency converters.
- Accident prevention can be attained by using, e.g. light barriers or end limit switches. In any event, provide an adequate brake path.
- The bearing temperatures must be monitored.

Maintenance (supplement ATEX)

In addition to the chapter maintenance (refer to Page 3) observe the following instructions about the application in potentially explosive areas:

- Tracks must be cleaned at regular intervals using an anti-static brush.
- The forming of corrosion on the tracks must be prevented.
- No potentially explosive atmospheres must be present for maintenance tasks or any adjustment necessary !
- One-sided starting of the wheel sets against the track system must be prevented.



Note:

The ATEX-Directive is only applicable for a temperature range of -20 °C to +60 °C. As necessary, at higher ambient temperatures, measurements must be carried out at the wheel blocks.

Installation dimensions of the wheel block RB 400

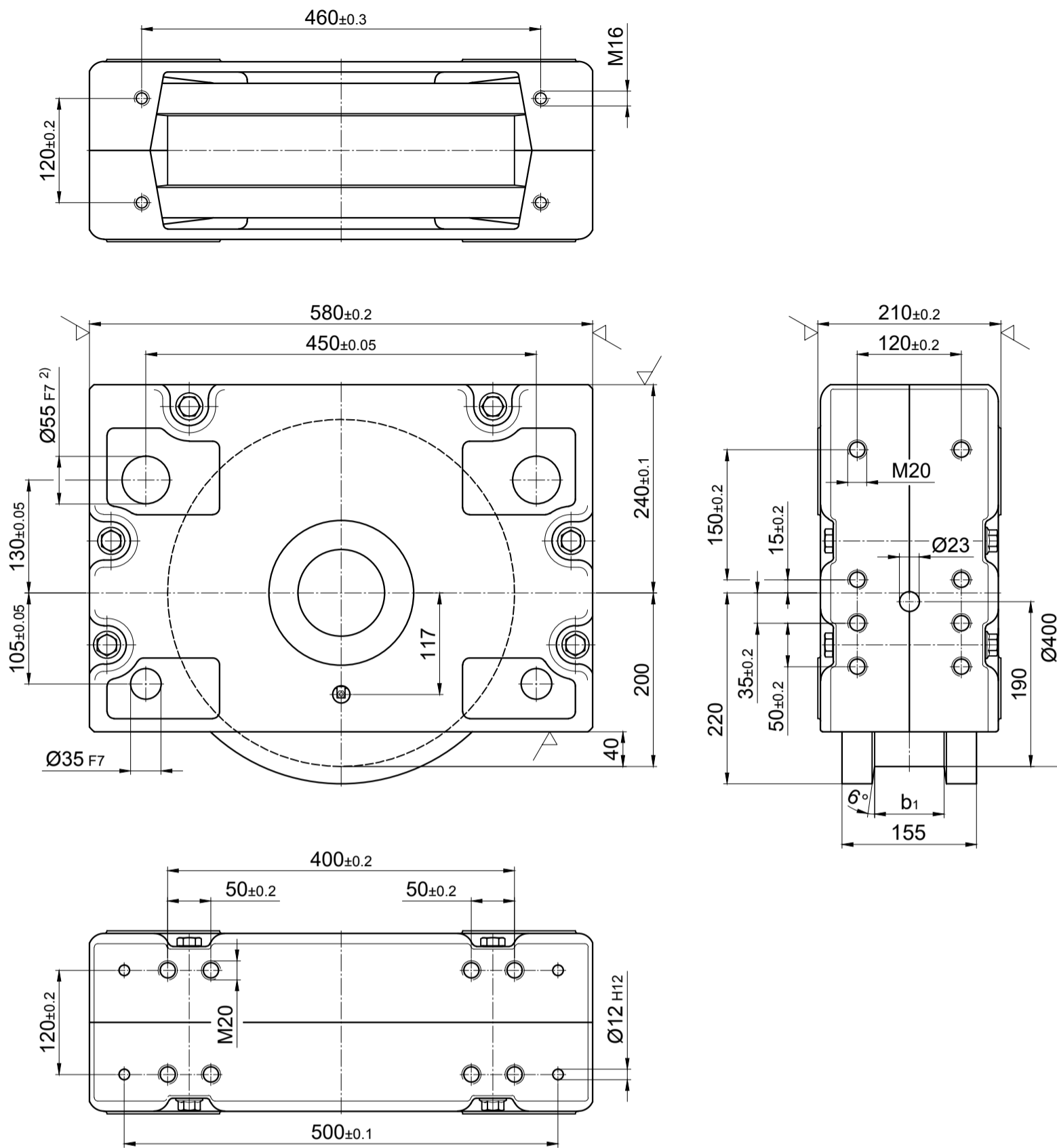

Wheel block driven

Wheel block not driven

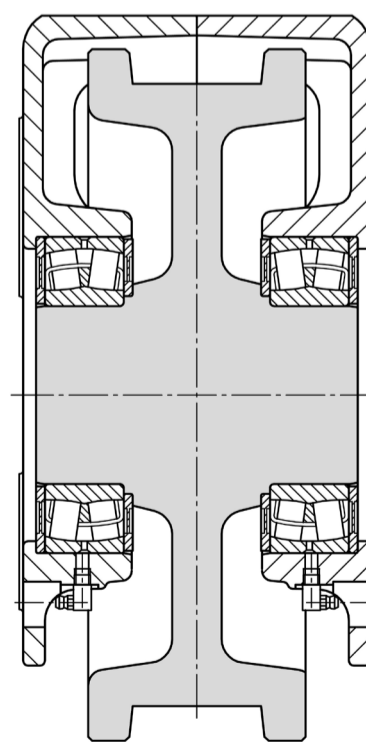
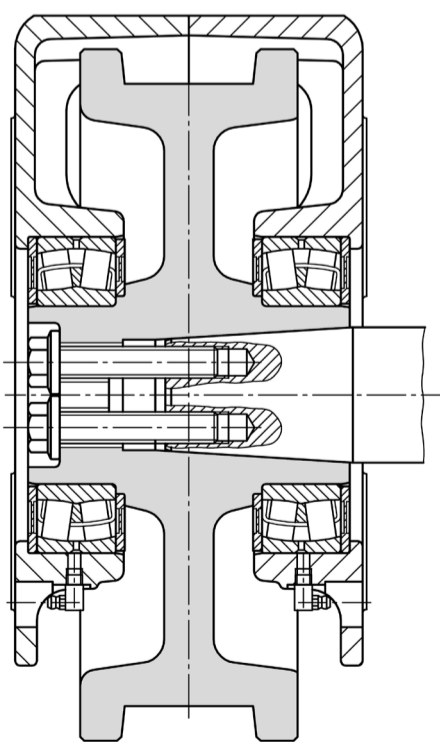

RBA 400

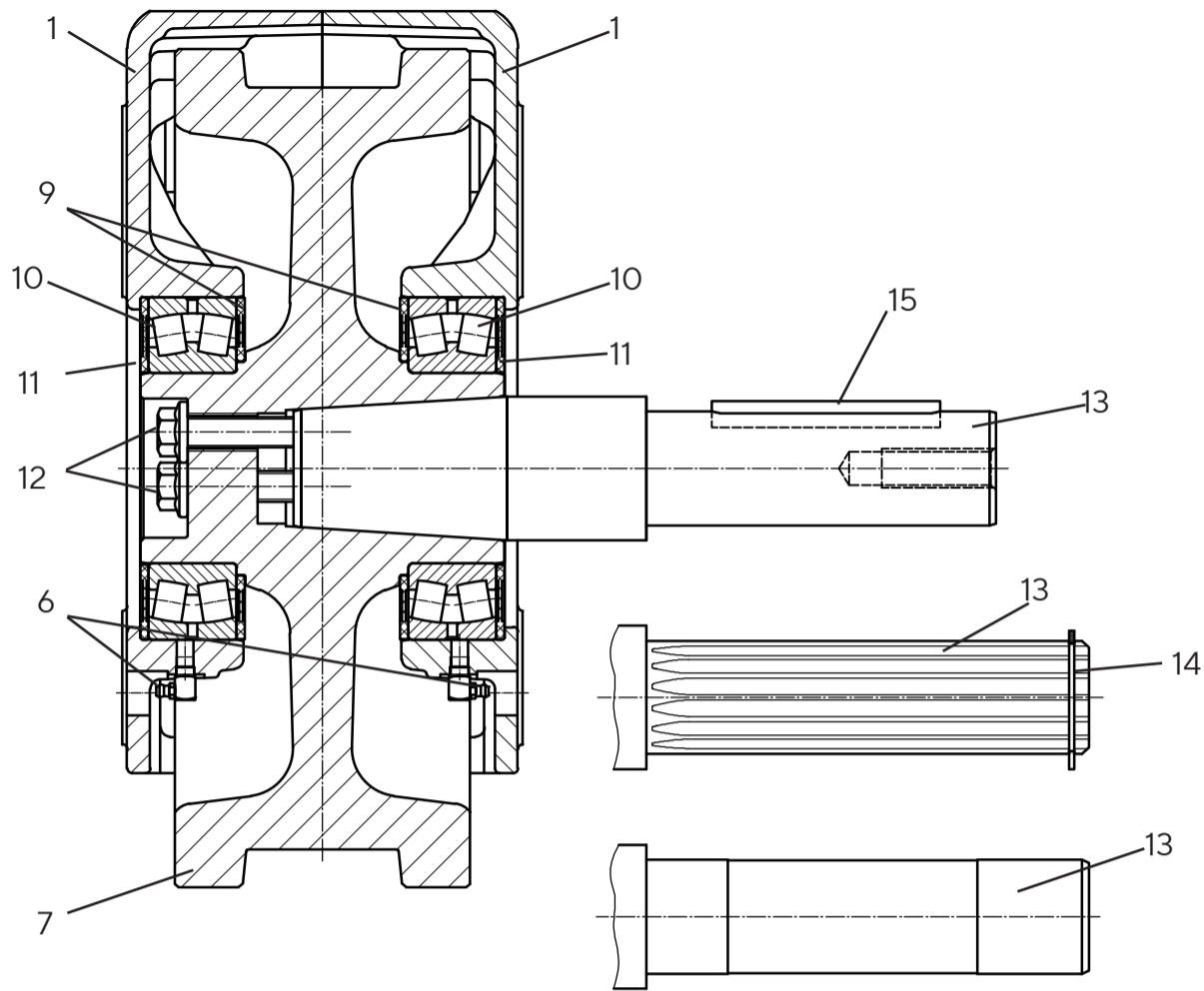

Special sealing for higher temperatures

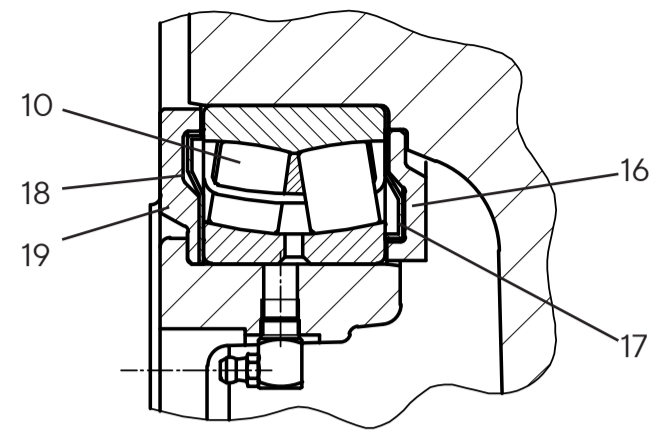

RBN 400

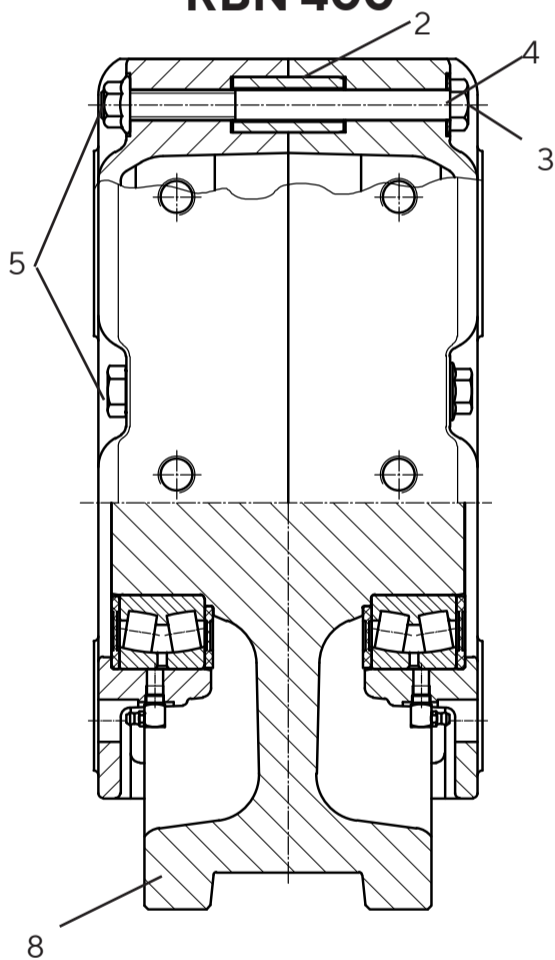

Part No.	Quantity	Designation
1	2	Housing halves RB 400, EN-GJS-400
2	4	Locking pin 30 x 60, 55 Si7, DIN EN ISO 8752
3	6	Hexagon head bolt M 16 x 190, DIN 931, 10.9
4	6	Disc spring 31,5 x 16,3 x 2, DIN 2093
5	6	Safety nut M 16, 10
6	2	Lubrication nipple C R1/8" DIN 71412
7	1	Crane wheel RBA 400, EN-GJS-700
8	1	Crane wheel RBN 400, EN-GJS-700
9	2	Sealing disc, inner, POM
10	2	Self-aligning roller bearings 222 20 DIN 635-2
11	2	Sealing disc, outer, POM
12	3	Locking bolt M 16 x 80, 12.9
13	1	Drive shaft
14	1	Circlip DIN 471/DIN 983
15	1	Feather key DIN 6885/1
16	2	Protective disc, inner, C 45
17	2	Nilos ring 222 20 AV
18	2	Nilos ring 222 20 IV
19	2	Protective disc, outer, C 45

Top connection KA 400.1

Direct connection as bolted fitting (for e.g. roller profiles, welded construction etc.)

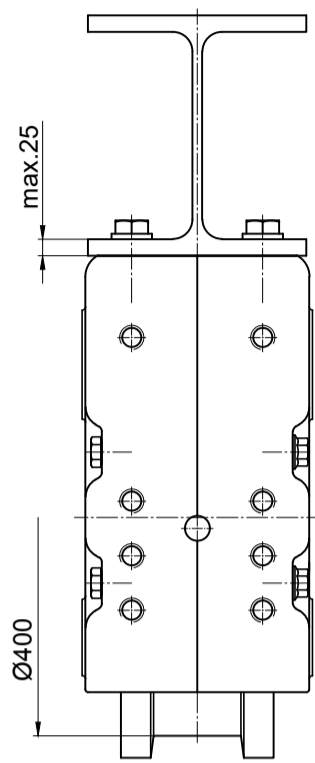
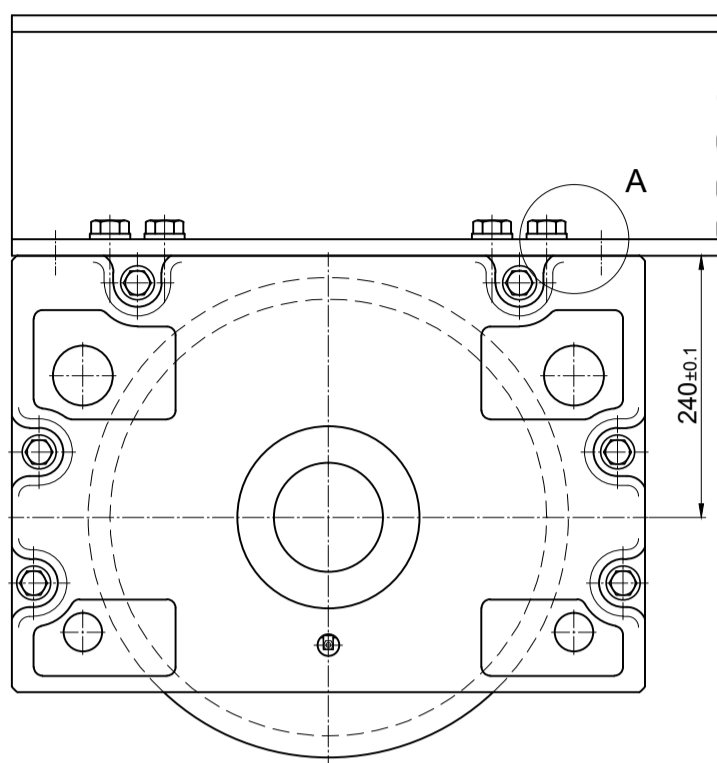

Order example:

1 Set KA 400.1

1 Set Connection elements for Top connection KA 400.1 consist of:

- 8 Hexagon head bolts
M 20 x 55, 10.9 DIN EN ISO 4017
- 8 Discs Ø 37/20,5 x 5
- 4 Locking pins 12 x 30
DIN EN ISO 8752

Hole pattern of connection design for precise fitting variant

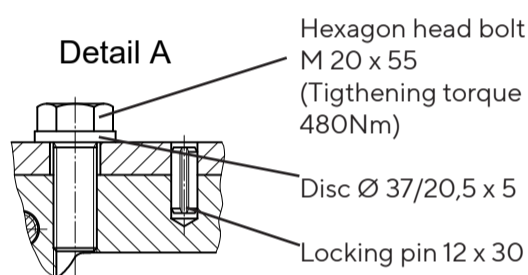
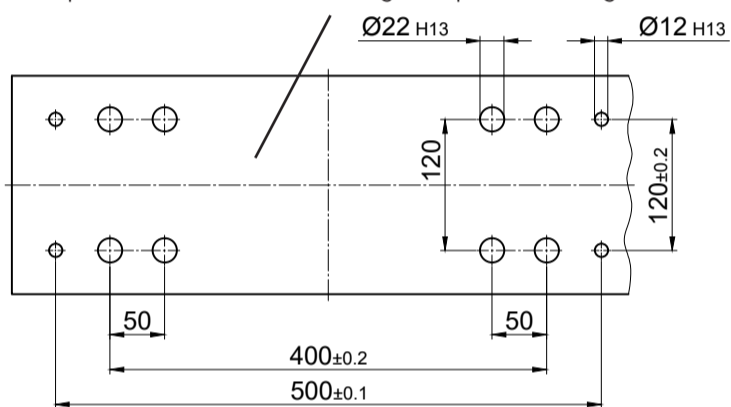

Connection options

- Precise fitting direct connection: Connection option **1** (see figure)
- Adjustable direct connection: Connection option **2**

The connection option 1 requires a precise agreement of the hole pattern on the wheel block and connection design (refer to Fig.)! In order to prevent positional errors and, thus, premature wear of the crane wheels, the attaching surfaces must be exactly aligned with the connection holes on the system.

If the connection holes cannot be exactly produced, connection must be carried out in accordance with connection option 2 (hole pattern, refer to Page 11).

Installation procedure

Connection option 1:

1. Position the wheel block against the connection holes of the connection design.
2. Insert the locking pins 12 x 30.
3. Install locking bolts M20 x 55 (tightening torque 480 Nm).

Connection option 2:

1. Position the wheel block against the connection holes of the connection design.
2. Install locking bolts M20 x 55 hand tight.
3. Exactly align the wheel block on the system, in order to prevent positional errors and, thus, premature wear of the crane wheels. Alignment can be carried out using the machined side surfaces of the wheel block.
4. Tighten locking bolts M20 x 55 (tightening torque 480 Nm).
5. Drill the holes for the locking pins and insert the locking pins (e.g. 12 x 30).
Pinning is not permitted in the area of the bores Ø 12 and in the area of connection bolt of the wheel blocks.

Top connection KA 400.2

Direct connection as bolted fitting (for e.g. roller profiles, welded construction etc.)

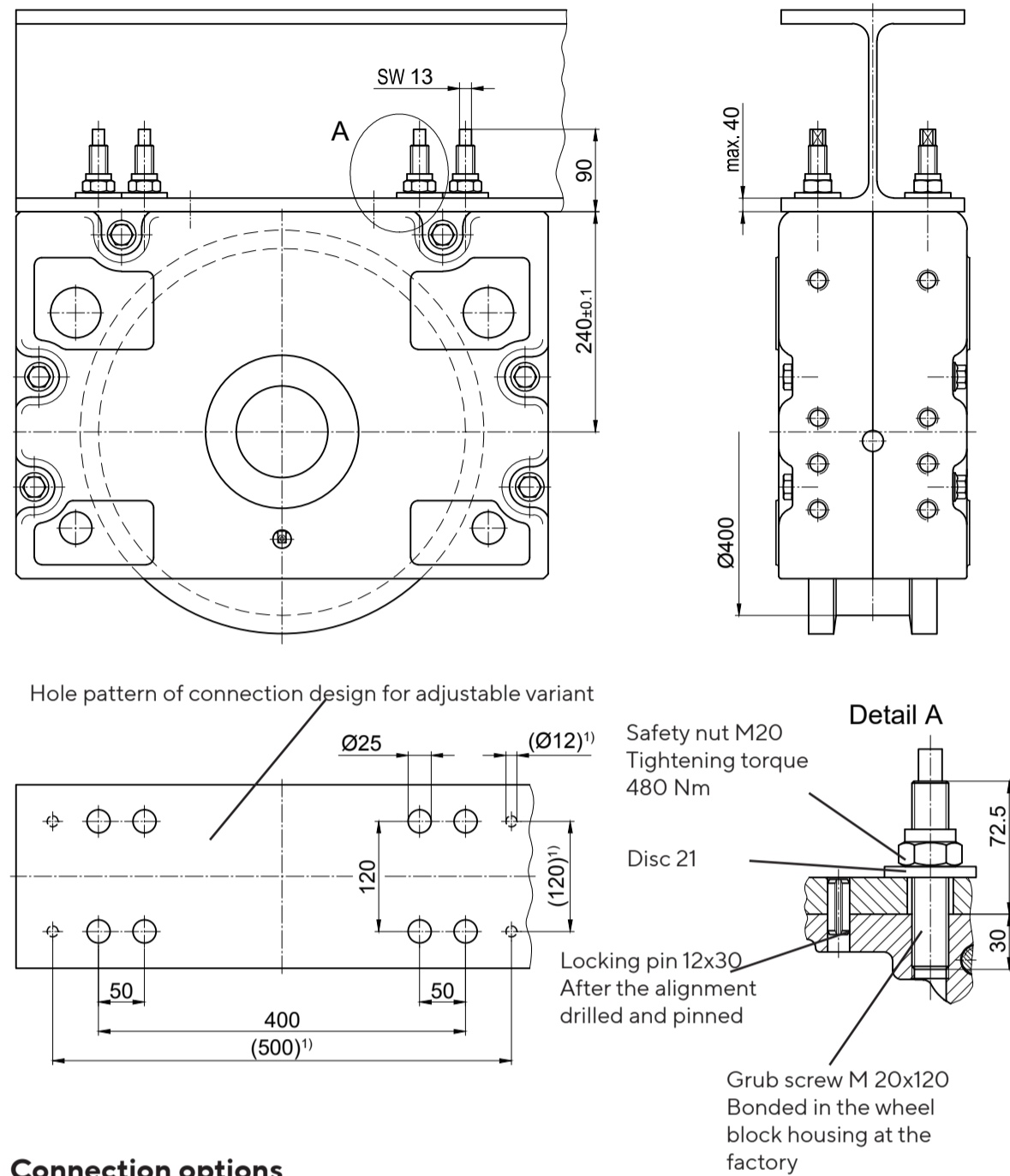

Order example:

1 Set KA 400.2

1 Set Connection elements for Top connection KA 400.2 consist of:

8 Grub screw M 20x120 - 10.9ZT
 8 Safety nuts M20 - 10
 DIN EN ISO 7042
 8 Discs 21 DIN 6340
 4 Locking pins 12x30
 DIN EN ISO 8752
 for adjustable connection

Longer grub screws are available on request.

Connection options

- Precise fitting direct connection: Connection option 1
- Adjustable direct connection: Connection option 2 (refer to Fig.)

Connection option 1 requires the hole patterns on the wheel block and connection design to match exactly (hole pattern Page 10)! In order to prevent positional errors and, thus, premature wear of the crane wheels, the attaching surfaces must be exactly aligned with the connection holes on the system.

If the connection holes cannot be exactly produced, connection must be carried out in accordance with connection option 2.

Installation procedure

Connection option 1:

1. Install the wheel block with bonded grub screws in the connection holes for the connection design.
2. Insert the locking pins 12 × 30
3. Install the safety nuts M20 with discs (tightening torque 480 Nm).
When doing this, hold the grub screws across the width across flats!

Connection option 2:

1. Install the wheel block with bonded grub screws in the connection holes for the connection design.
2. Install the safety nuts M20 with discs and hand tighten.
3. Exactly align the wheel block on the system, in order to prevent positional errors and, thus, premature wear of the crane wheels. Alignment can be carried out using the machined side surfaces of the wheel block.
4. Tighten safety nuts M20 (tightening torque 480 Nm). Hold the grub screws across the width across flats!
5. Drill Ø12 H13 holes for the locking pins 12 × 30 and insert the locking pins.
Pinning is not permitted in the area of the bores Ø 12 and in the area of connection bolt of the wheel blocks.

Side connection WA 400

Lateral connection option for low construction designs

Connection option 1:

Connection design is accessible from both sides

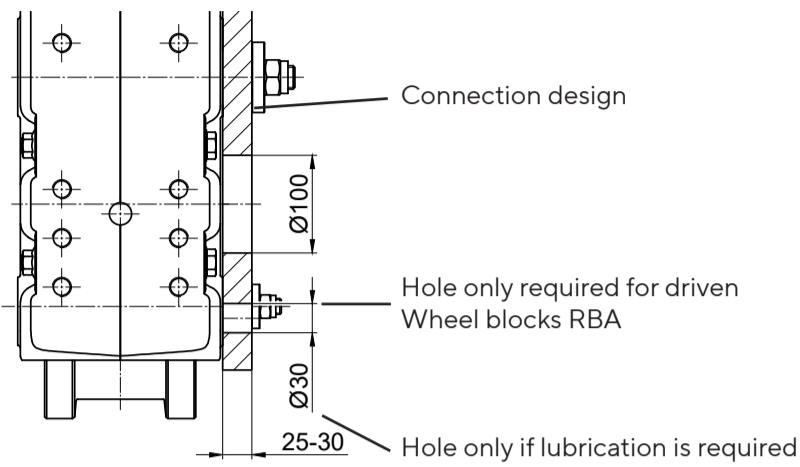

Schnittansicht

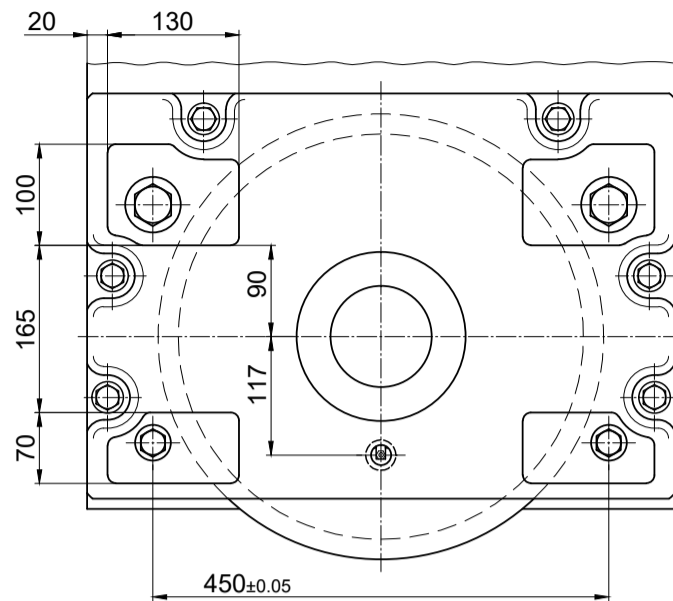

23

Connection option 2:

Connection design and hollow profile is not accessible from inside

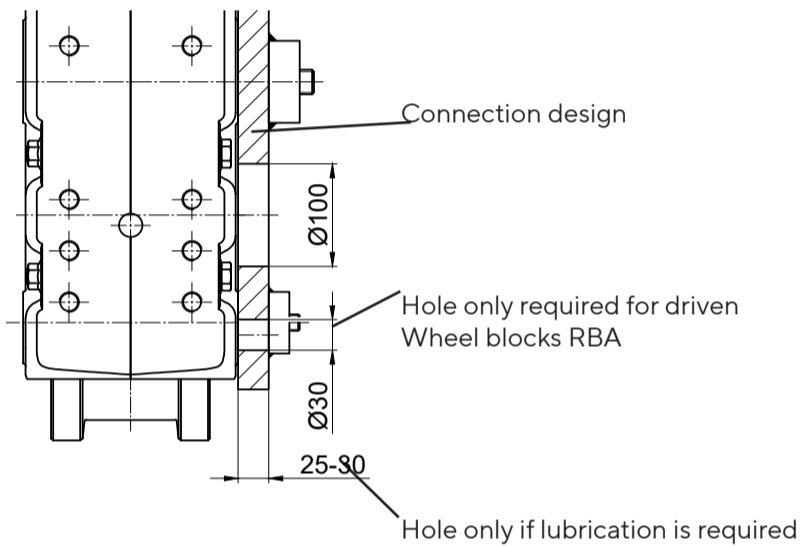

Schnittansicht

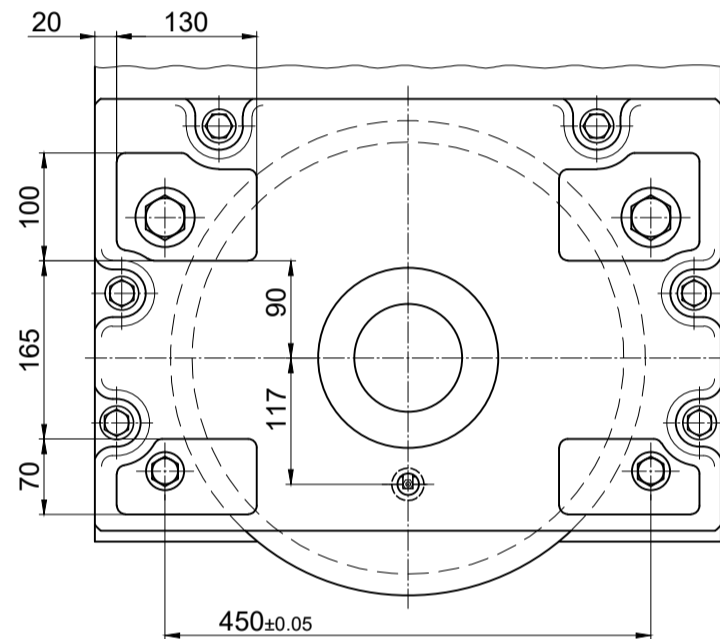

Connection option 1:

Through-hole $\text{\O}55^{\text{H12}}$ and
Through-hole $\text{\O}35^{\text{H12}}$

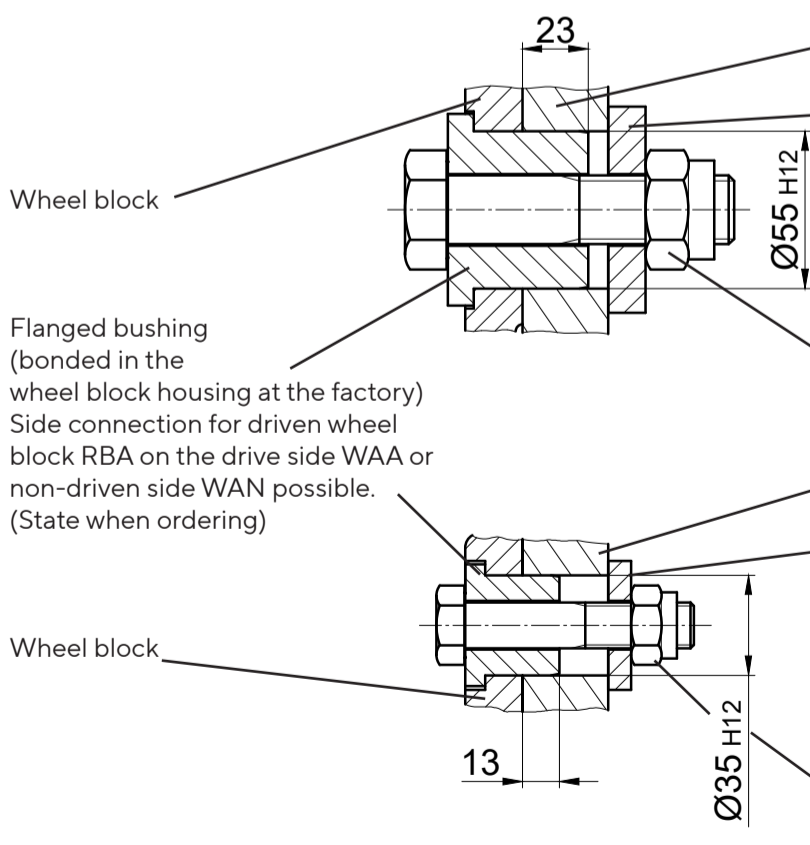

Connection option 2:

Blind bore hole $\text{\O}55^{\text{H12}}$ x 25 deep with M 24 thread and
Blind bore hole $\text{\O}35^{\text{H12}}$ x 15 deep with M 16 thread

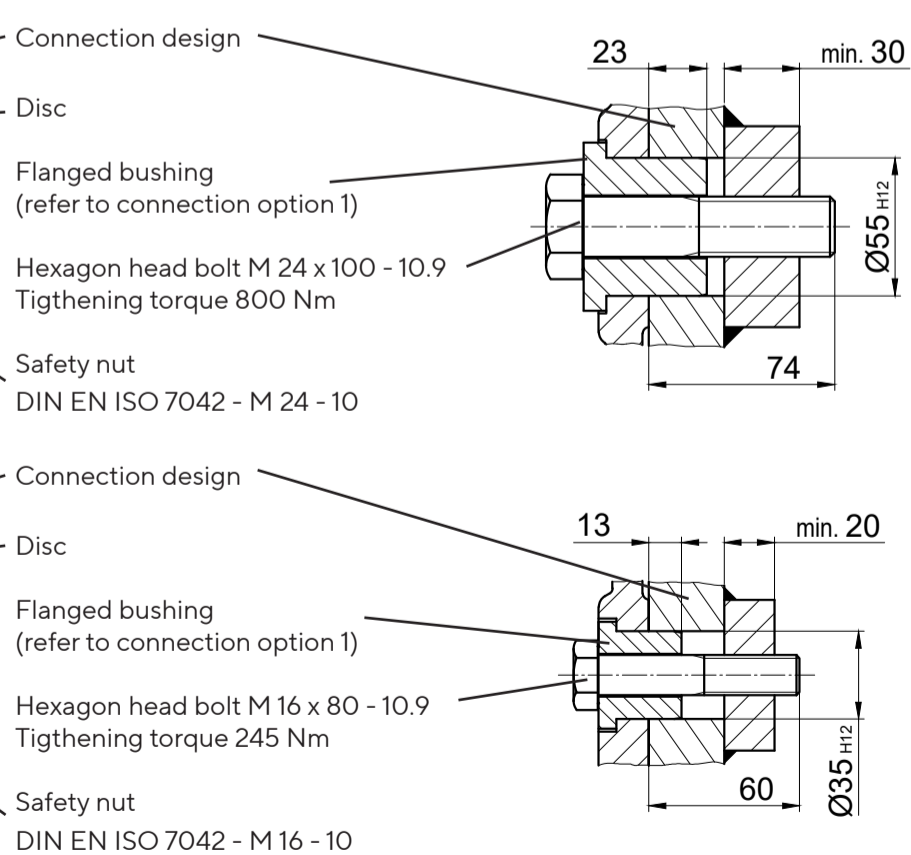

<p>1 Set of connection elements for Side connection WA 400 consist of:</p> <p>2 flanged bushings 55, boneded at the factory</p> <p>2 Hexagon head bolts M 24 x 100, 10.9 DIN EN ISO 4014</p> <p>2 Safety nuts M 24 DIN EN ISO 7042</p> <p>2 Discs 25</p> <p>2 flanged bushings 35, bonded at the factory</p> <p>2 Hexagon head bolts M 16 x 80, 10.9 DIN EN ISO 4014</p> <p>2 Safety nuts M 16 DIN EN ISO 7042</p> <p>2 Discs 17</p>	<p>Order example:</p> <p>1 Set WAA 400 (Side connection on the drive side)</p> <p>1 Set WAN 400 (Side connection on the non-driven side)</p> <p>1 Set WA 400 (Side connection on the non-driven- Wheel block RBN)</p>
---	---

Installation procedure

The connection surface of the connection design for the wheel block must be so even that the wheel block cleanly rests on the machined surfaces (if necessary, machine). In order to prevent positional errors and, thus, premature wear of the crane wheels, the connection surfaces must be exactly aligned on the system.

Connection option 1

(Connection design is accessible from both sides)

1. Install the wheel block with the two bonded flanged bushings into the locating holes $\varnothing 55^{H12}$ and $\varnothing 35^{H12}$ and press against the connection design.
2. Use a socket wrench to insert locking bolts M 24 × 100 and M 16 × 80 through the holes in the opposite drilled holes in the housing in the wheel block.
3. Install the $\varnothing 25$ and 17 discs and the M 24 and M 16 safety nuts.
4. Use a torque wrench and tighten the safety nuts.
Torque of M 24 800 Nm M 16: 245 Nm

Connection option 2

(Connection design is only accessible from the front)

1. Install the wheel block with the two bonded flanged bushings into the locating holes $\varnothing 55^{H12}$ and $\varnothing 35^{H12}$ and press against the connection design.
2. Use a socket wrench to screw locking bolts M 24 × 100 and M 16 × 80 through the holes in the opposite drilled holes in the housing in the wheel block.
3. Use a torque wrench and tighten the locking bolts.
Torque of M 24 800 Nm M 16: 245 Nm

Pin connection BA 400.1

Installation variant with pin connection (hollow profiles, floating levers, etc.)

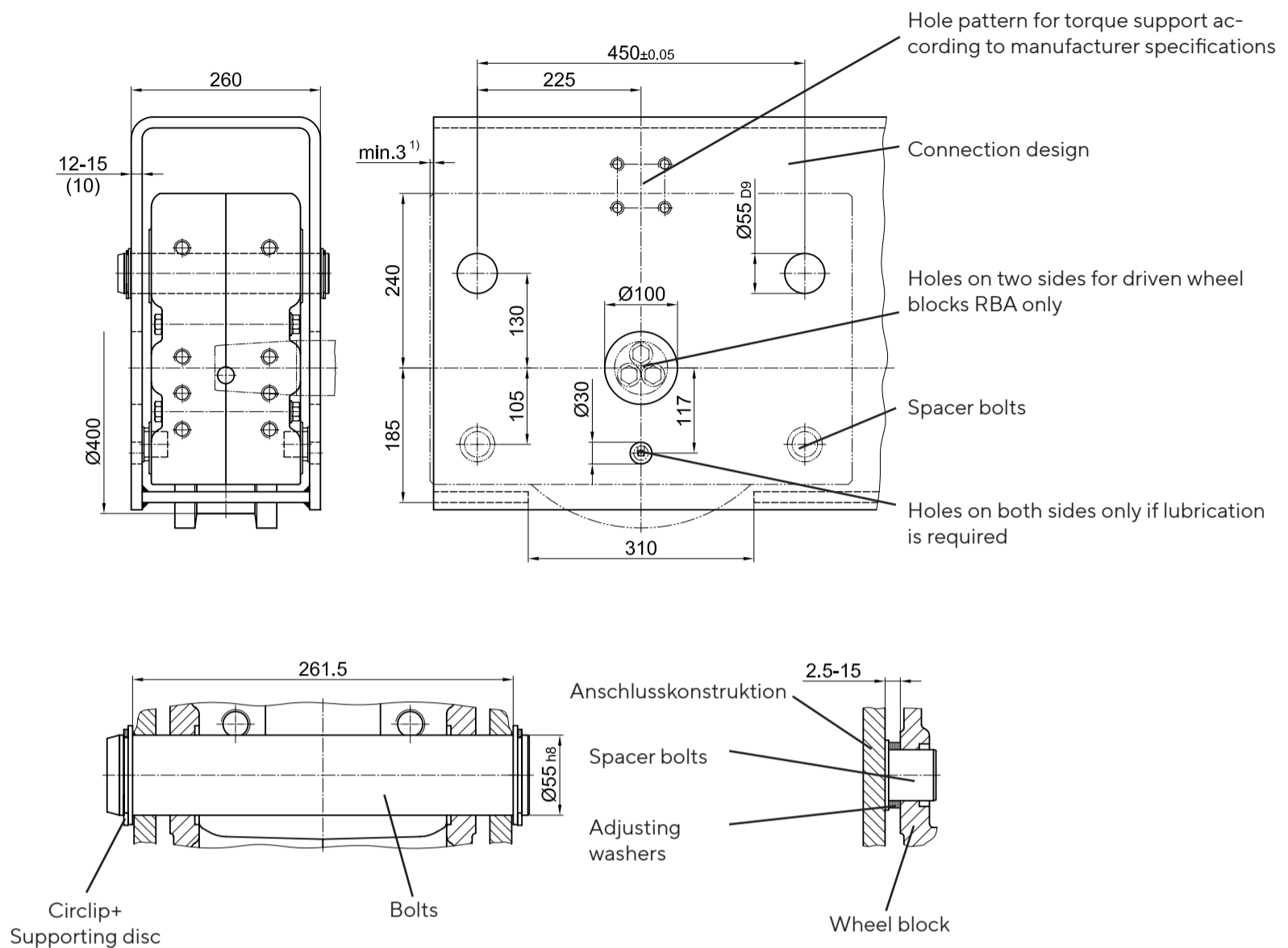

- 1 Set Connection elements for Pin connection BA 400.1 consist of:
- 2 Bolts Ø 55
- 4 Circlips 55 x 3 DIN 471
- 4 Supporting disc S 55 x 68 DIN 988
- 4 Spacer bolts
- 100 Adjusting washers 35x45x0,5 DIN 988

Order example:

1 Set **BA 400.1**



In order to prevent positional errors and, thus, premature wear of the crane wheels the holes Ø 55^{D9} for attaching the wheel block must be exactly drilled to one another and precisely align the wheel block in the connection design. Before setting the track, or at initial installation, the wheel block must be relieved.

You set the track or centre the wheel block in the connection design by changing the shims onto the spacer bolts.

Installation procedure

1. Determine the thicknesses of the shims and insert the spacer bolts into the bottom four Ø 35 drilled holes of the wheel block using the appropriate number of shims.
2. Insert the wheel block as tightly as possible into the connection design.
3. Use two bolts to attach the connection design to the wheel block through the top Ø 55 holes.
4. Install circlips and supporting discs to axially secure the bolt.

Pin connection BA 400.2

Installation variant with pin connection (hollow profiles, floating levers, etc.)

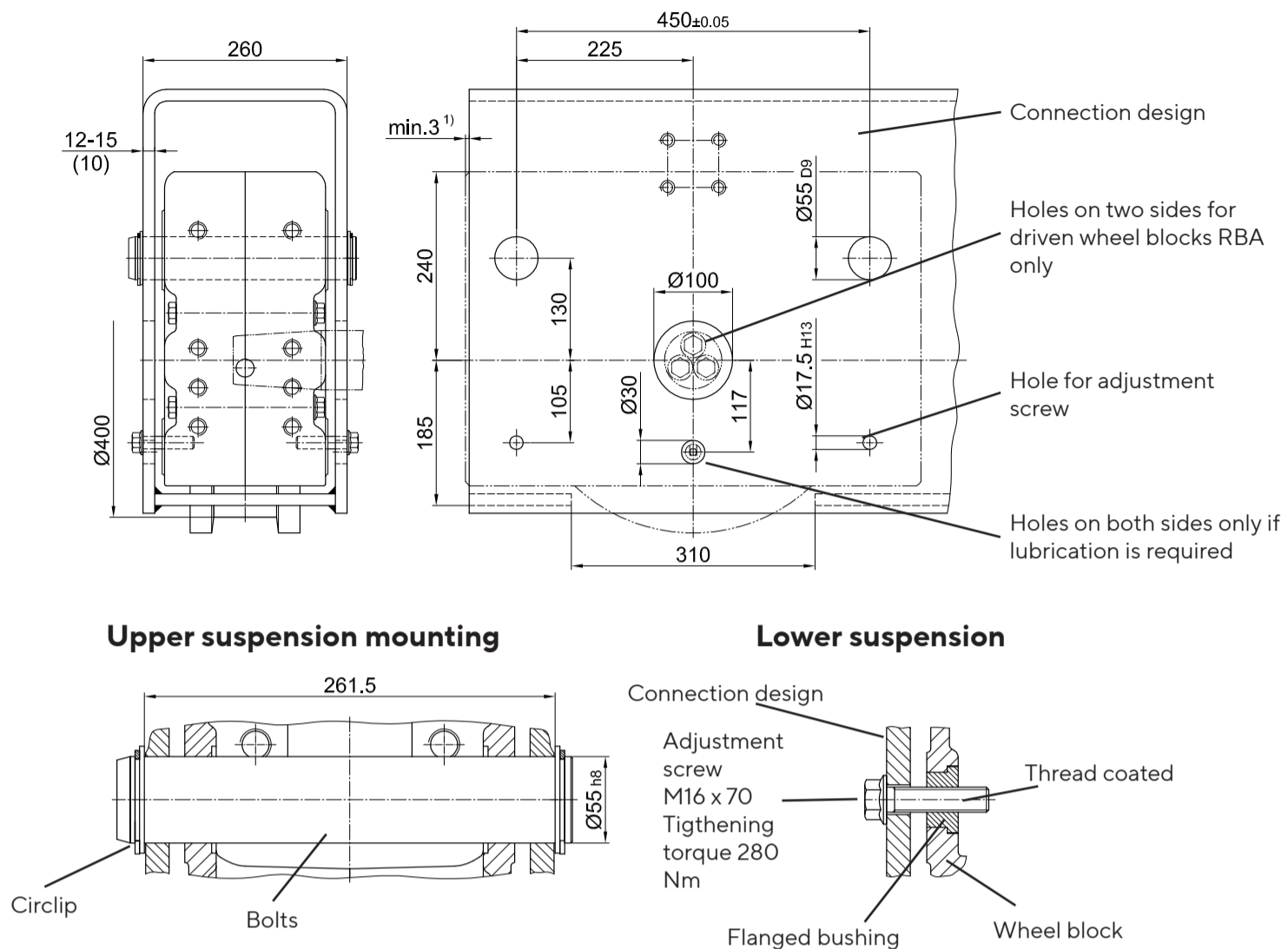

- 1 Set Connection elements for Pin connection BA 400.2 consist of:
- 2 Bolts Ø 55
- 4 Circlips 55 x 3 DIN 471
- 4 Supporting disc S 55x68 DIN 988
- 4 Flanged bushing with internal thread (bonded)
- 4 Locking bolts M 16 x 70, 10.9 (coated)

Order example:
1 Set **BA 400.2**



In order to prevent positional errors and, thus, premature wear of the crane wheels the holes $\text{Ø} 40^{\text{D9}}$ for attaching the wheel block must be exactly drilled to one another and precisely align the wheel block in the connection design. Before setting the track, or at initial installation, the wheel block must be relieved.

Installation procedure

1. Insert the wheel block in the connection design.
2. Use two bolts to attach the connection design to the wheel block through the top $\text{Ø} 40$ holes.
3. Install circlips and Supporting discs to axially secure the bolt.
4. Install two M16 × 70 adjustment screws on one side through the holes in the connection design into the wheel block. By tightening the adjusting screws (tightening torque max. 280 Nm), pull the wheel block into the required (horizontal) position.
Option for correction: Release the adjustment screws along the correction path, install the other two adjustment screws on the opposite side and pull the wheel block back into position.
5. When the required position is reached, tighten all adjustment screws (tightening torque 280 Nm max.)

Installation of cellular plastic buffer

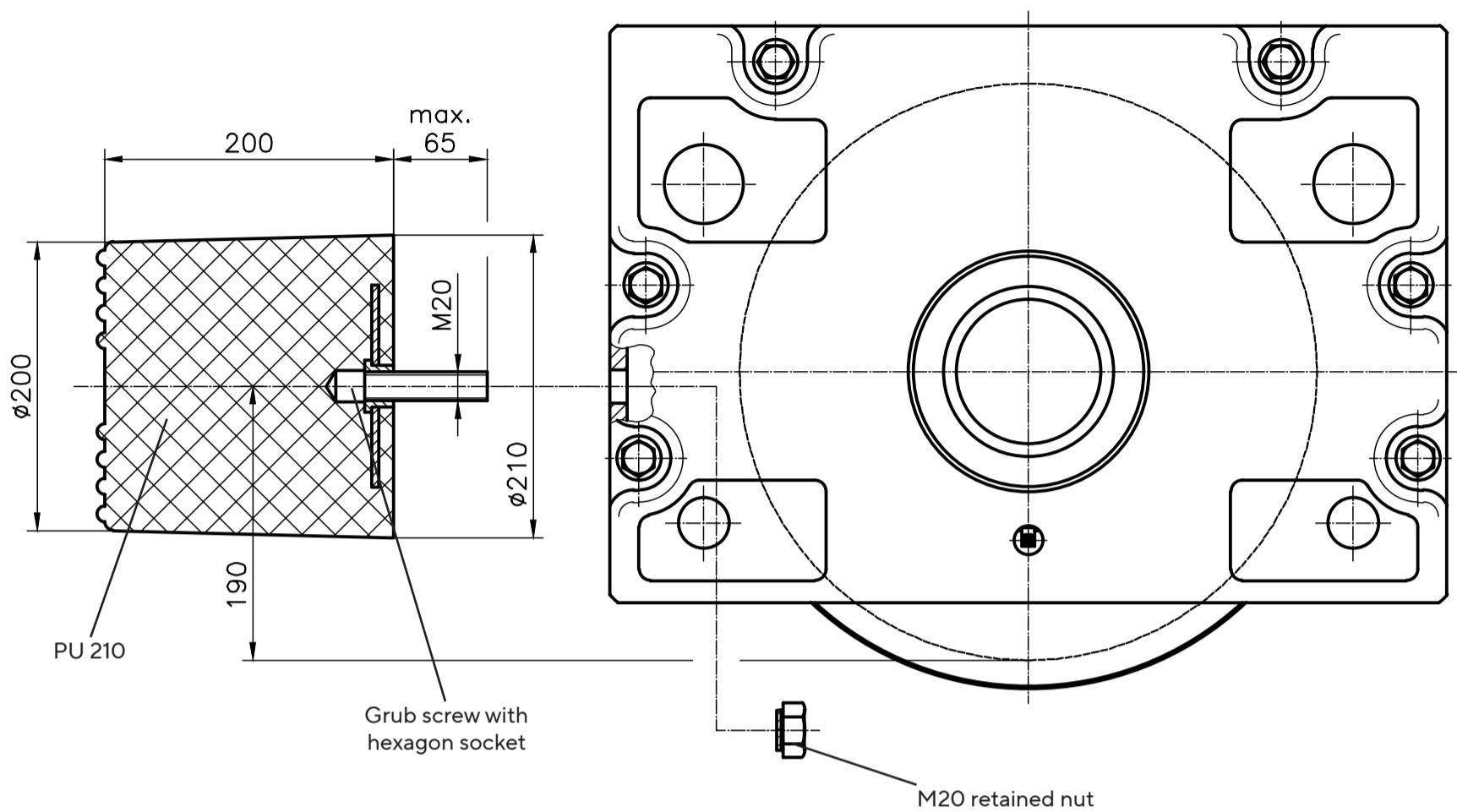

Included in the scope of delivery:

- 1 Cellular plastic buffer
- 1 Grub screw
- 1 Retained nut

Order example:

- 1 Cellular plastic buffer **Pu 210**

Installation procedure

1. Route the M20 retained nut from the inside to the corresponding drilled hole and draw it from outside into the wheel block housing using an M20 bolt.
2. Screw the M20 grub screw into the buffer.
3. Screw the buffer into the retained nut in the wheel block with the grub screw.

Installation of the drive shaft

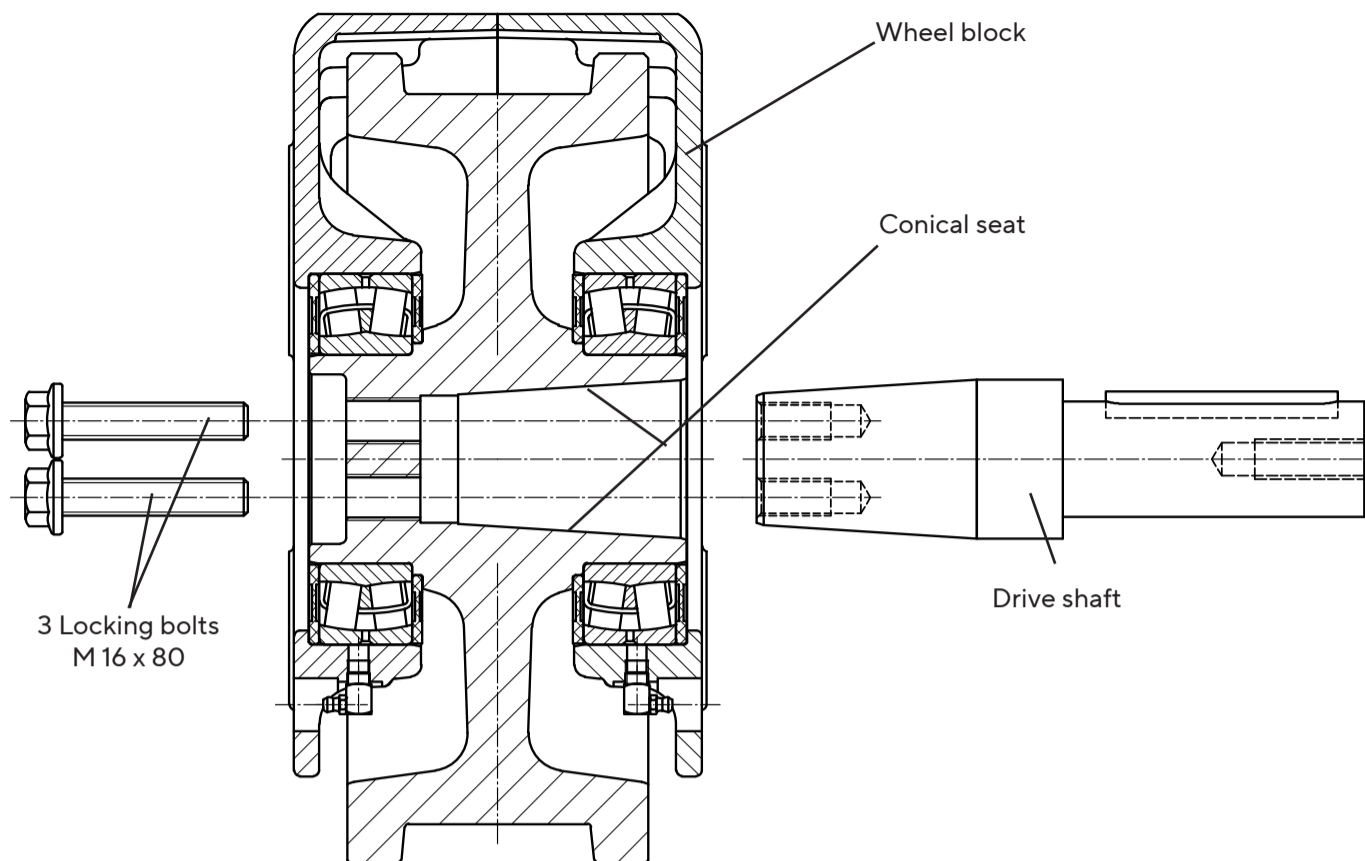

Included in the scope of delivery:

- 1 Drive shaft
- 3 Locking bolt
- 1 Circlip bzw. Feather key

For ordering, state the gearbox type, shaft journal and manufacturer information.

Order example:
1 Drive shaft 400
400 - W 50 x 2 x 24 x 1

Installation procedure

To prevent fretting corrosion, the drive shaft is electrogalvanized and the conical seat in the crane wheel has a bonded coating.

Attention! Do not damage the coating of the conical seat, if damaged replace (Molykote D 321 R spray on thin and uniform).

1. Insert the drive shaft into the crane wheel.
2. Install the connection bolts
3. Insert the drive shaft into the cone by tapping it lightly with a hammer (aluminium hammer, copper bolt) and tighten the connection bolt using a torque wrench (tightening torque 360 Nm) (Repeat the procedure).
4. Apply a coat of roller bearing grease in the area of the slip-on gear mechanism.
5. Push on the slip-on gear mechanism and attach as specified by the manufacturer.
6. After 3 to 6 operating hours or approx. 100 load reversals, use a torque wrench and tighten the connection bolts (tightening torque 360 Nm).

Removal of the Drive shaft

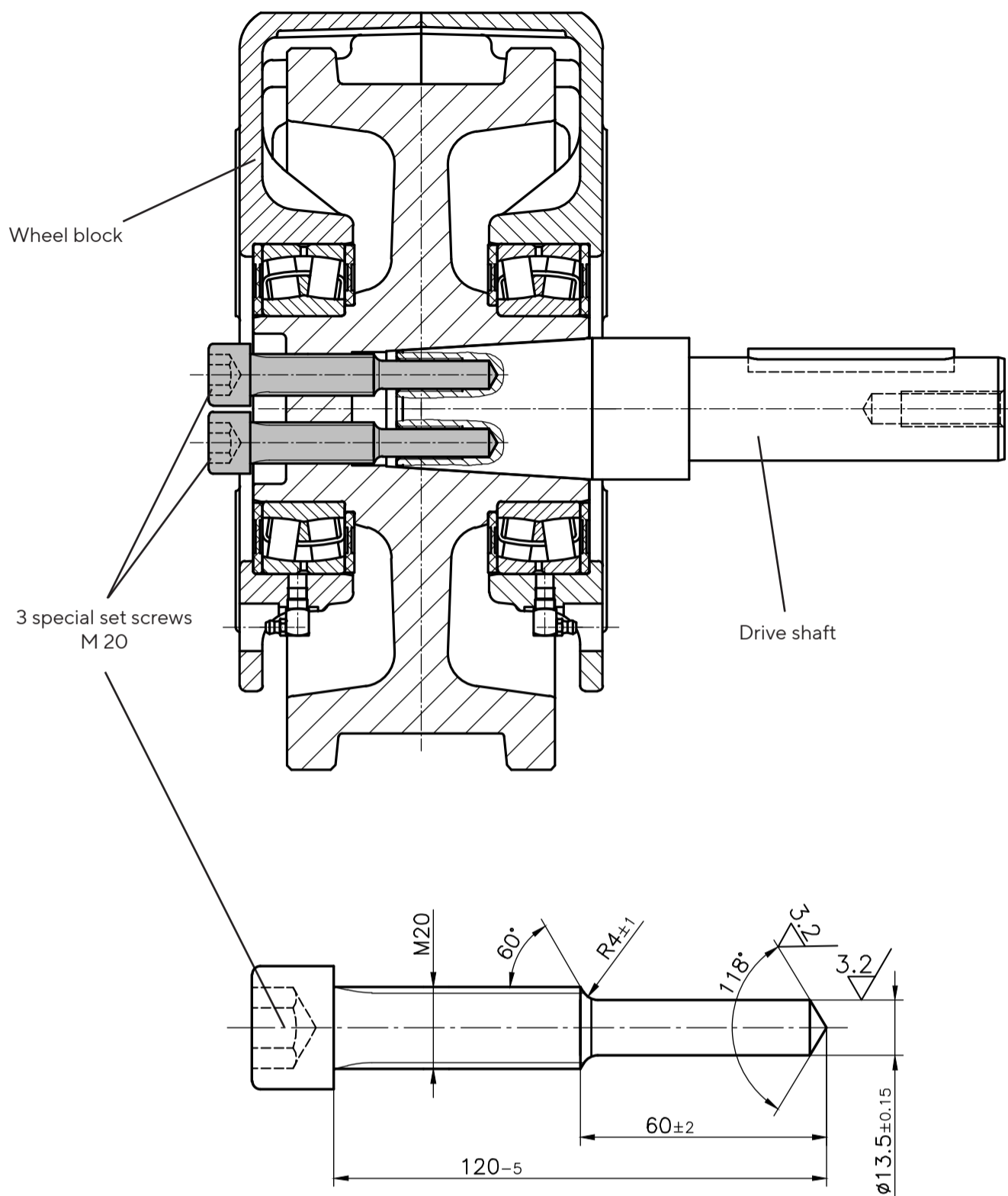

Removal procedure

It is necessary to use a special set screw M20 to easily remove the drive shafts.

1. Remove the connection bolt (refer to the figure "Installation of the drive shaft").
2. Release the slip-on gear mechanism at the torque support and pull from the drive shaft.
3. Use a hexagon socket wrench and insert special set screw M 20 into the crane wheel (lubricate thread and point of bolt with grease). Thereby, the drive shaft is pressed from the cone.

Installation and removal of the central drive

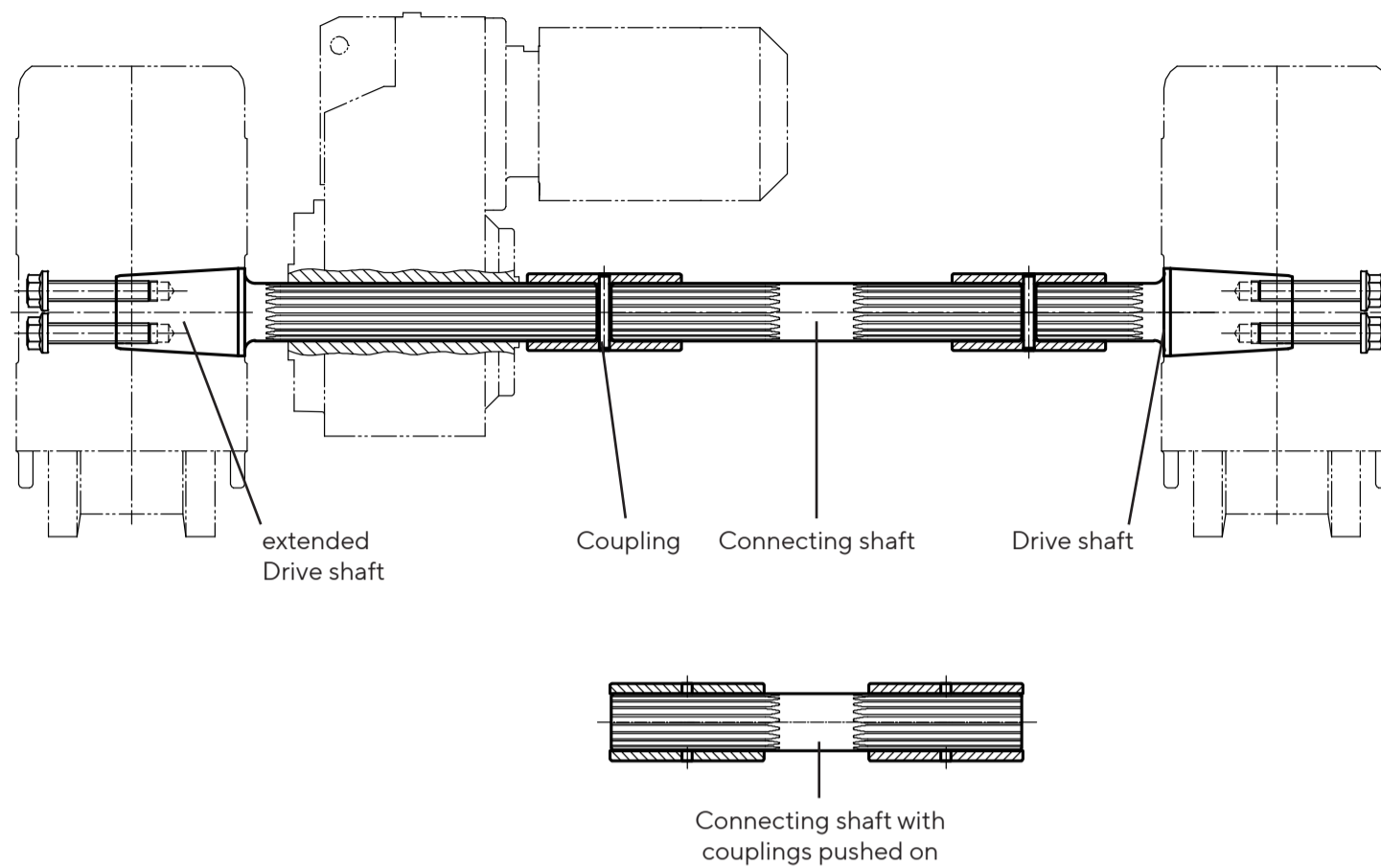

Included in the scope of delivery:

- 1 Drive shaft ZAA
- 1 Drive shaft ZAM
- 6 Locking bolts
- 2 Couplings with clamping sleeve
- 1 Connecting shaft

When ordering, always state the gearbox type or the splined-shaft profile and the average track dimension L.

Order example:

1 Central drive 400
W 50 x 2 x 24 - 1 - L (L=average track dimension)

Installation procedure

1. Install the drive shafts in accordance with the instructions "Installation of the drive shaft".
2. Apply a coat of roller bearing grease to the drive shafts and connecting shaft in the area of the slip-on gear mechanism and couplings.
3. Push on the slip-on gear mechanism and attach as specified by the manufacturer.
4. Push the couplings onto the connecting shaft on both sides (refer to Fig. above)
5. Place the connecting shaft with couplings between the drive shafts and push the couplings half way onto the drive shafts.
6. Secure the couplings by hammering in the $\varnothing 8$ clamping sleeves.

Removal is carried out in the reverse order.

Removal of the wheel block

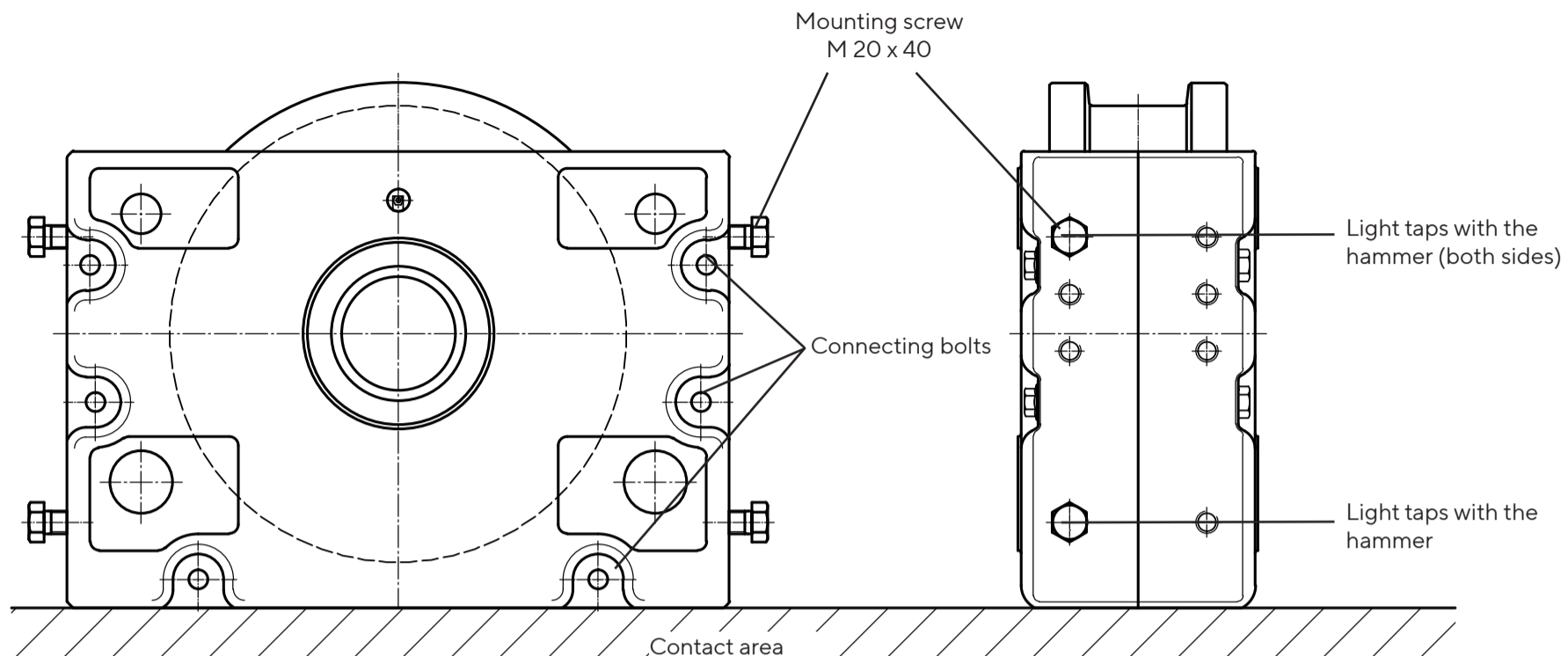

Removal procedure

1. Lay down the wheel block on the head side, or clamp in a vice.
2. Remove six connection bolts.
3. Screw in four M 20 × 40 screws approx. 20 mm into one half of the housing at the front.
4. The halves of the housing are separated by lightly tapping on both assembly screws alternately. As soon as a gap appears between both halves of the housing, the wheel block housing can be also prised apart using a suitable tool.
5. Remove the halves of the housing (1) from the self-aligning roller bearings.
6. Remove the sealing discs (11) halves of the housing.
7. Using a suitable extractor, pull the self-aligning roller bearing (10) from the hubs of the crane wheel. Thereby, the extraction hook of the extractor should be inserted between the bearing and seal disc (9).
8. Replace the self-aligning roller bearing and seal discs.

Dismounting device

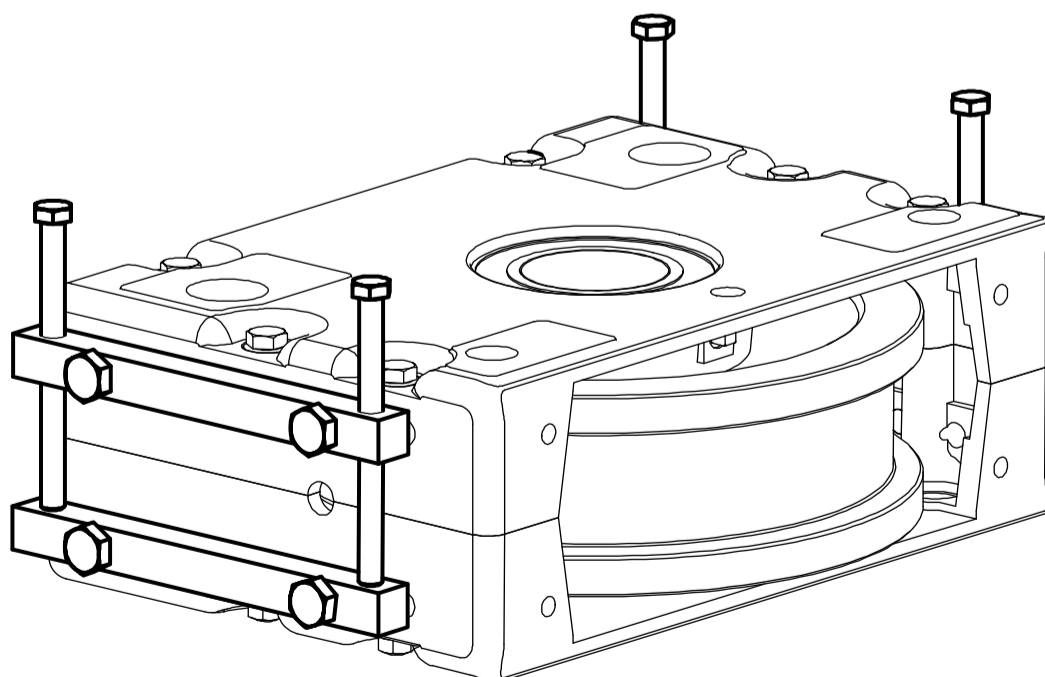

Further information and details of pricing and delivery periods are available on request!

Installation of the wheel block

Installation procedure

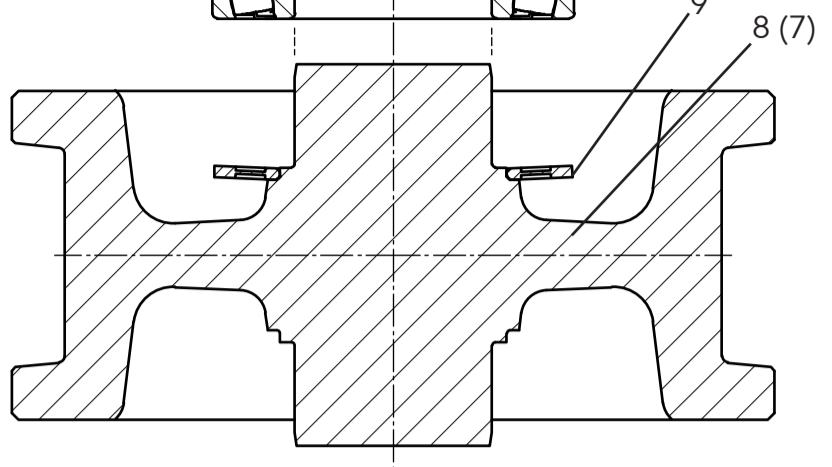
1. Place the crane wheel (7) and (8) horizontally.
 2. Install the inner seal disc (9) with the convex outer diameter upwards.
 3. Press on the self-aligning roller bearing (10).
- 
4. Turn over the crane wheel and assemble on the other side of the hub as in 2. and 3.
 5. Place one half of the housing (1.1) on the flank connection surface.
 6. If not installed, insert in the 4 locking pins 30 × 60 (2).
 7. Install the outer seal disc (11.1) with the convex inner diameter upwards.
 8. Install the self-aligning roller bearing with crane wheel into the bore of the housing.
 9. Place the outer seal disc (11.2) on the self-aligning roller bearing with the convex inner diameter upwards.
 10. Push the second half of the housing (1.2) onto the self-aligning roller bearing until the housing halves touch the locking pins.
 11. Using a plastic or aluminium hammer and tap in the top half of the housing (1.2) in the area of the locking pins, or use an assembly press to press it in.
 12. Install six M 16 × 190 connection bolts (3, 4, 5).
 - Attention! Pay attention to the correct position of the disc spring (4) below the bolt head.
 13. Use a torque wrench to tighten the hexagon-headed bolts (3) (tightening torque 260 Nm).
 14. Lubricate the self-aligning roller bearing through the existing lubrication nipple (6) until grease escapes at the seal discs. During the lubrication procedure, turn the crane wheel.

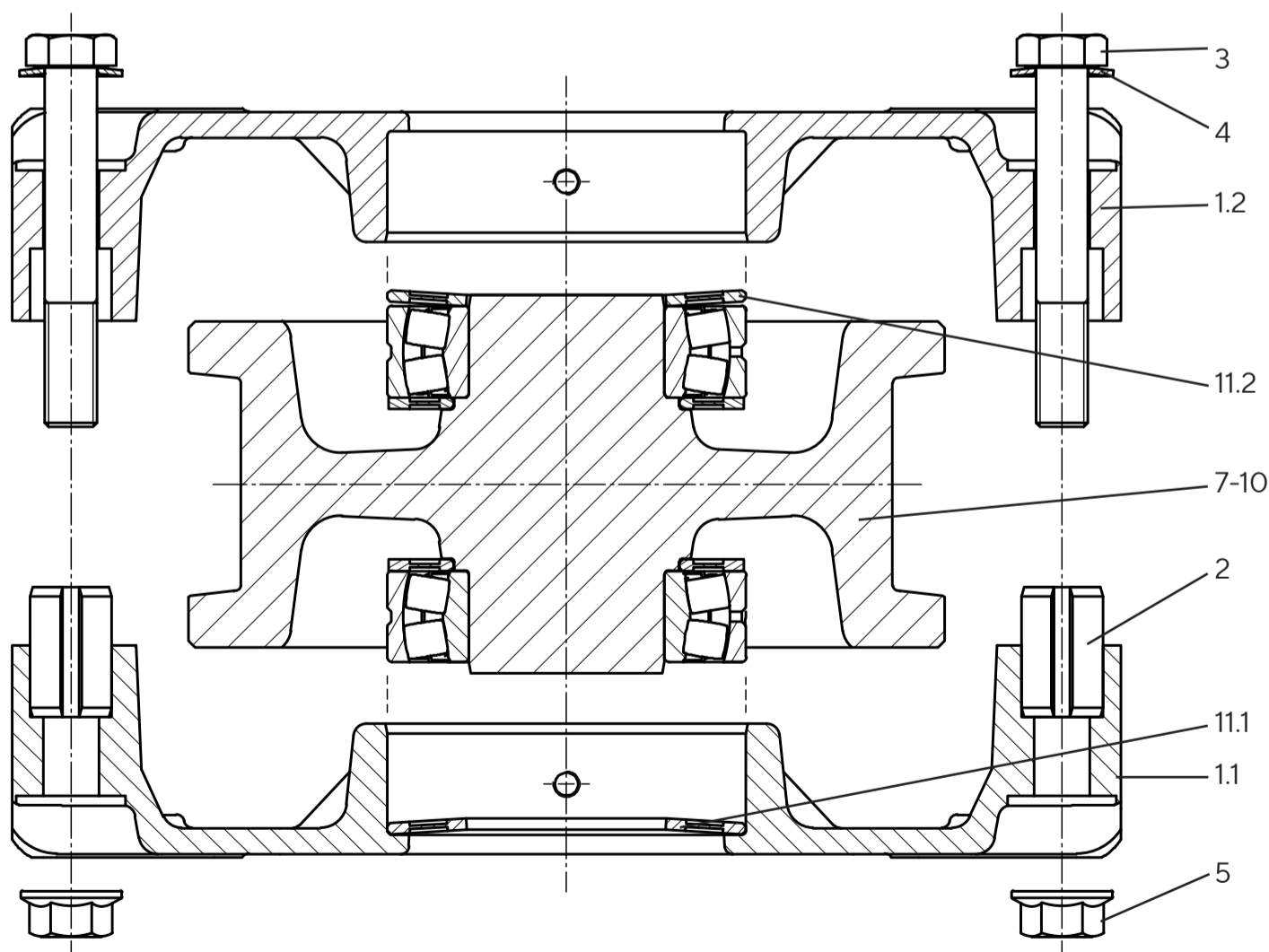

The wheel blocks with special sealing and for higher temperatures and/or ATEX are installed as previously described, however, instead of the plastic seal discs, Nilos rings (metal seals) and protective discs made from steel (Part 16 - 19) are installed.

Subsequently, lubricate roller bearings with suitable grease, refer to Page 3.

EG-Einbauerklärung *Declaration of Incorporation*

im Sinne der EG-Richtlinie 2006/42/EG, Anhang II B für unvollständige Maschinen
according to EC directive 2006/42/EC, Annex II B, in respect of incomplete machinery

Name und Anschrift des Herstellers / *Name and address of the manufacturer:*

Karl Georg GmbH
Karl-Georg-Straße 3
D - 57612 Ingelbach-Bahnhof

Hiermit erklären wir, dass die nachstehend beschriebene unvollständige Maschine:
Herewith we declare, that the partly completed machinery described below:

Produktbezeichnung/ product denomination : **Atlas Radblocksystem**
Atlas Wheelblocksystem

Serien- / Typenbezeichnung / model / type : **RB 160 - 500 mm**

Baujahr/ Year of manufacture : **2024**

alle grundlegenden Anforderungen der Maschinenrichtlinie 2006/42/EG erfüllt, soweit es im Rahmen des Lieferumfangs möglich ist. Ferner erklären wir, dass die speziellen technischen Unterlagen gemäß Anhang VII Teil B dieser Richtlinie erstellt wurden.

is complying with all essential requirements of the Machinery Directive 2006/42/EC, as far as the scope of delivery allows. Additional we declare that the relevant technical documentation is compiled in accordance with part B of Annex VII.

Folgende harmonisierte Normen sind angewandt / *the following harmonized standards have been applied:*

- DIN EN ISO 12100, Sicherheit von Maschinen/ *Safety of Machinery*
- DIN EN 13001 Teil 1...3-8, Krane - Konstruktion allgemein/ *Cranes - general design*
- DIN EN 13135, Krane - Sicherheit/ *Safety of cranes*

Der Hersteller verpflichtet sich die technische Dokumentation zur unvollständigen Maschine einzelstaatlichen Stellen auf begründetes Verlangen in PDF-Form zu übermitteln.

The manufacturer undertakes to submit the technical documentation relating to the incomplete machine to the relevant national authorities in PDF format on request.

Bevollmächtigter für die Zusammenstellung der relevanten technischen Unterlagen (EU-Adresse):

The person authorised to compile the relevant technical documentation (must be established within EU):

Herr (Mr.) Michael Kubalski, QM (Quality Department)

Die unvollständige Maschine darf erst dann in Betrieb genommen werden, wenn festgestellt wurde, dass die Maschine oder Anlage, in welche die unvollständige Maschine eingebaut werden soll, den Bestimmungen der Richtlinie 2006/42/EG über Maschinen entspricht und die EG-Konformitätserklärung gemäß Anhang II A ausgestellt ist.

The partly completed machinery must not be put into service until the final machinery into which it is to be incorporated has been declared in conformity with the provisions of Directive 2006/42/EC on Machinery, where appropriate, and until the EC Declaration of Conformity according to Annex II A is issued.

D-57612 Ingelbach/Bhf., 04.01.2024

Hees, Olaf, GF
Winkel, Tim, GF
Müller, Kevin, GF



Ort, Datum
Place, Date

Name, Vorname, Funktion
surname, first name, function

Unterschrift
Signature



Karl Georg GmbH
Karl-Georg-Straße 3
D-57612 Ingelbach-Bahnhof

T: +49 (0)2688 / 95 16 - 0
info@karl-georg.de
www.karl-georg.de

Subject to alterations by the manufacturer for the purposes of further technical development!

Thus, no claims can be derived from the information, figures and descriptions given in these operating instructions.

© 09/2024 Karl Georg GmbH

Reprinting, duplication or translation, also as extract, is not permitted without previous written consent of Karl Georg GmbH. All rights are expressly reserved for Karl Georg GmbH according to the copyright law. Subject to alterations

Printed in Germany